

Powerful Solutions For Welding And Cutting Automation.

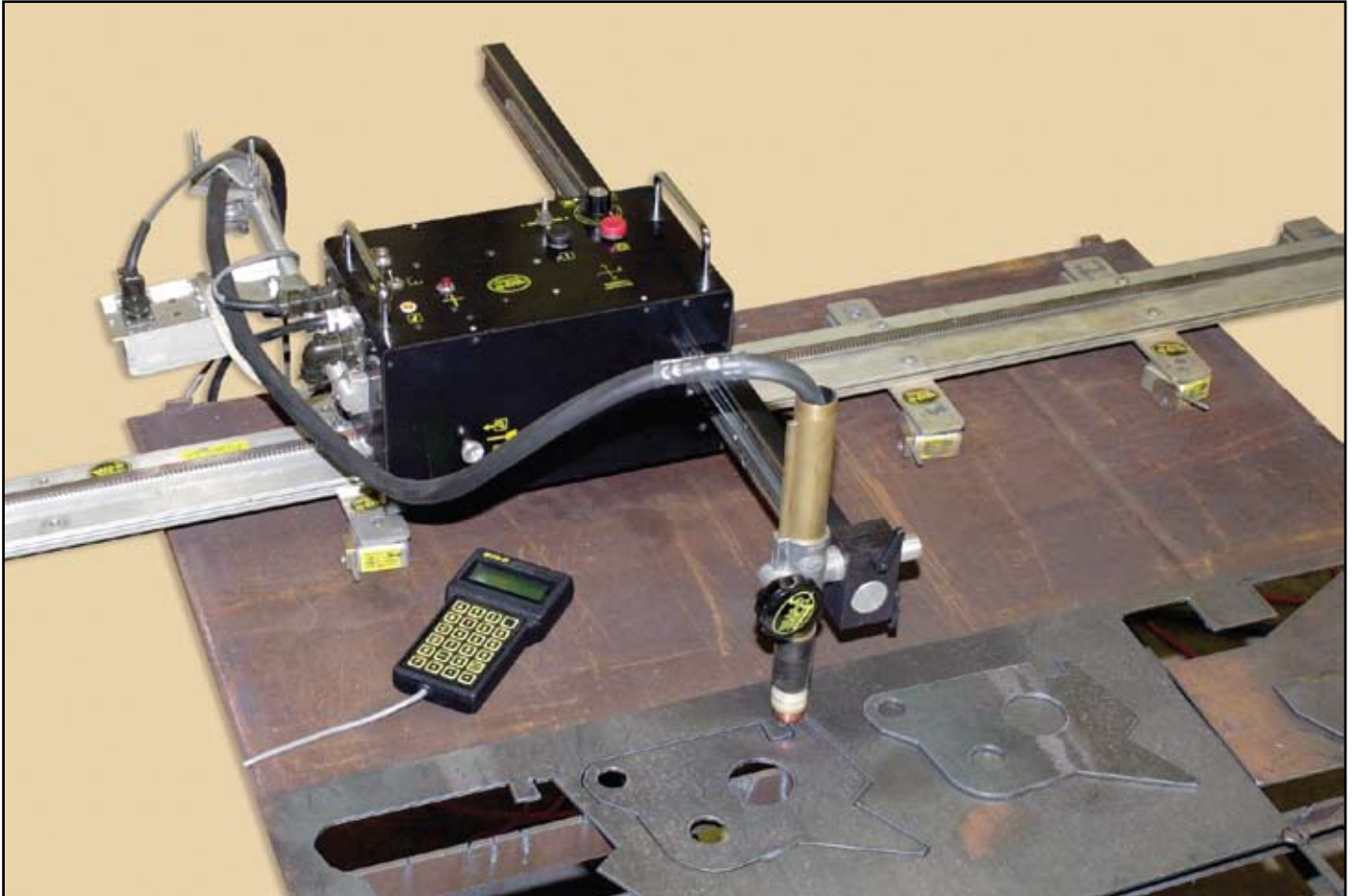

# PROGRAMMABLE SHAPE MACHINE

**Burn Virtually Any Shape, Weld Any Pattern,  
Quickly And Easily, In Any Position...**



The BUG-6150 Programmable Shape Machine is an easy to use 2-axis machine which you can program to run any contour or pattern for both welding or cutting applications. A handheld terminal supplied with the machine is used to program the required shape and operation sequence. Other functions besides moves can be programmed, such as repeats, starts, stops, delays, and rapid traverse. 20 programs can be stored in machine memory at any one time.

An optional computer software program is available, for any IBM compatible computer. With this program you can select pre-programmed shapes or create your own custom shapes, and store any number of them on disk. Selected shapes can then be downloaded to the machine as needed.

The Programmable Shape Machine is compact and lightweight and can be easily carried throughout your facility. It is held in position with either powerful permanent magnets or vacuum cups, depending on the work material. This enables you to take the machine to the work, which will help reduce your material handling.

*PATENTS WORLDWIDE*



**BUG-O SYSTEMS**  
A DIVISION OF WELD TOOLING CORPORATION



280 TECHNOLOGY DRIVE CANONSBURG, PENNSYLVANIA 15317-9564 USA  
PHONE: 1-412-331-1776 <http://www.bugo.com> FAX: 1-412-331-0383



# PROGRAMMABLE SHAPE MACHINE

The Programmable Shape Machine is a two-axis machine that runs on a track and carries a torch on a motorized cross-arm. It can be used for flame or plasma cutting, or welding, of a variety of shapes which are programmed and stored in memory.

All programming is done with the handheld terminal provided. The terminal can be plugged into the connector on the rear of the machine or unplugged at any time. The terminal is not needed to run the machine once programmed.

The machine has storage capacity in memory for 20 different programmed shapes. At any time, one of these shape numbers is selected to be active, and will stay selected even when the power is shut off, and turned back on, until the shape number is changed by the machine operator.

Shapes and patterns are built up using segments. To do this, select the type of segment you want and determine what quadrant it is in – type it into the terminal. Any given shape can have up to 50 segments. Other functions such as weld/oxygen, on/off, time delay, or repeat a shape a number of times, also count as one segment each, if used.

## Handheld Terminal Functions:

The programming operation is selected by pressing keys **A, B, C, D, or E.**

**A: ALL SEGMENTS;** data entry for new shape consists of total number of segments and data for each segment.

**B: PROGRAM SEGMENT;** press **B** on terminal to re-program a single segment. This is useful if there is an error in data for just one segment, so that the whole shape does not have to be re-entered.

**C: CHANGE SHAPE NUMBER;** press **C** on terminal to change the current shape number. The program switches to the new number in memory, and to whatever shape is stored there.

**D: DISPLAY SHAPE DATA;** press **D** to display the data for the current shape. The terminal display shows a total number of segments, and data for each segment one by one each time you press enter.

**E: END OF SEGMENT SLOWDOWN;** press **E** to set value of deceleration for the shape, when the machine approaches the end of each segment. This is useful when the shape has sharp corners to prevent overshoot. **99** is maximum slowdown, **0** is no slowdown.

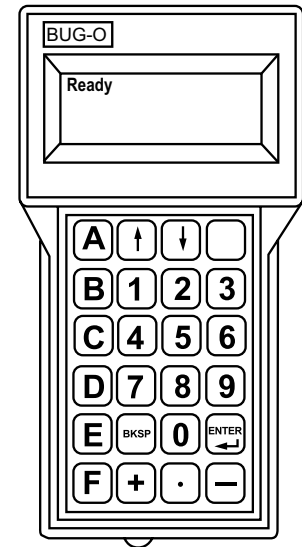

The different types of segments that can be loaded into the machine are as follows:

Clockwise 90		Clockwise Partial Arcs	
Counter Clockwise 90		Counter Clockwise Partial Arcs	
X or Y Axis		Inclined Lines	

Other functions besides the moves shown above are:  
Weld Contact/Solenoid On/Off, Pause, Delay, Repeat another shape, Full ellipse, and Rapid Traverse.



# PROGRAMMABLE SHAPE MACHINE

## Operation:

The machine is in the reference start position, when first plugged in.

There are 3 options (the handheld terminal is not needed for the first two):

1. **MOVE:** To change the home position, push the STOP/PAUSE button, move the machine manually to the required position using the joy stick, and push the reset button.
2. **RUN:** Push the START/RUN button to cut/weld a shape.
3. **PROGRAM:** The programming operation requires the use of the handheld terminal.

## Technical Data:

<b>Power Requirements:</b>	BUG-6150	120VAC/50-60/1
	BUG-6152	240VAC/50-60/1
	BUG-6154	42VAC/50-60/1
<b>Travel Speed:</b>	2.5-50 ipm (63-1250 mm/min)	
<b>Cross Travel:</b>	24" (610 mm)	
<b>Max. Segment Dimension:</b>	72" (1800 mm) Within Limits of Travel	
<b>Min. Increment Dimension:</b>	.01" (0.1 mm)	
<b>Delay Increment:</b>	.01 seconds	
<b>Net Weight Of Drive Unit:</b>	37 lbs. (17 kg)	
<b>Dimensions Of Drive Unit:</b>	15.0"L x 8.25"W x 10.0"H (381 mm x 210 mm x 255 mm)	

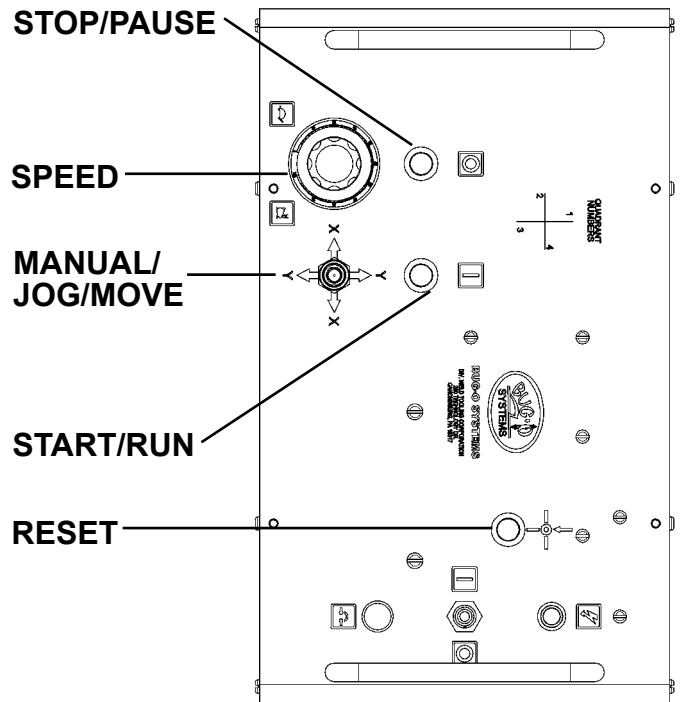

## COMPUTER SOFTWARE

The Programmable Shape Machine can be programmed from a PC, using either of two software packages described below. Shapes can be created off-line, and downloaded to the machine when required. A cable is supplied to connect to the serial port of the PC.

### 1. PC Option / BUG-6140.

This runs under Windows, and allows you to:

- Create shapes on the PC.
- Save any number of shapes to disk, and retrieve them as necessary.
- View a programmed shape on screen - which helps program verification.
- Download programmed shapes from the PC to the machine.

### 2. BUG-6240 CAD Interface.

This is a complete package that includes both the PC option and DeskCNC. This will allow you to take 2 dimensional CAD drawings and convert them to Shape files that you can directly load into your shape machine.

- DeskCNC is used to modify 2 dimensional CAD drawings (.DXF files) and create a toolpath
- The toolpath is saved as a shape file using DeskCNC
- The shape file can be loaded in the PC option for easy integration with the shape machine



# PROGRAMMABLE SHAPE MACHINE

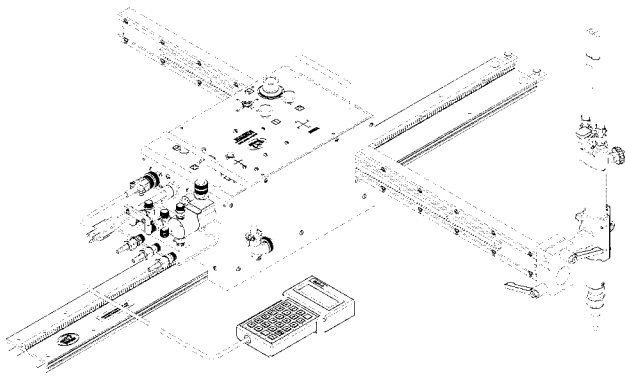

**BUG-6200**     **PROGRAMMABLE SHAPE OXY-FUEL CUTTING KIT 120VAC/50-60/1**

- Includes:**  
 1 BUG-6150 Programmable Shape Machine and Handheld Terminal  
                   2.5-50 ipm (63-1250 mm/min)  
 1 BUG-6090 Q.A. Manifold w/Solenoid 120 VAC  
 1 BUG-6155 Cutting Group

**BUG-6202**     **PROGRAMMABLE SHAPE CUTTING KIT 240VAC/50-60/1**

**BUG-6204**     **PROGRAMMABLE SHAPE CUTTING KIT 42VAC/50-60/1**

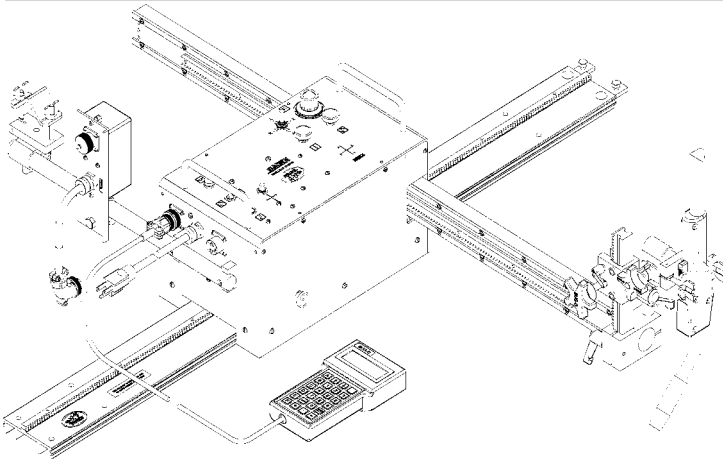

**BUG-6201**     **PROGRAMMABLE SHAPE WELDING KIT 120VAC/50-60/1**

- Includes:**  
 1 BUG-6150 Programmable Shape Machine and Handheld Terminal  
                   2.5-50 ipm (63-1250 mm/min)  
 1 BUG-6080 Relay Box w/Cable Anchor [To Control Arc On/Off]  
 1 BUG-6145 Welding Group

**BUG-6203**     **PROGRAMMABLE SHAPE WELDING KIT 240VAC/50-60/1**

**BUG-6205**     **PROGRAMMABLE SHAPE WELDING KIT 42VAC/50-60/1**

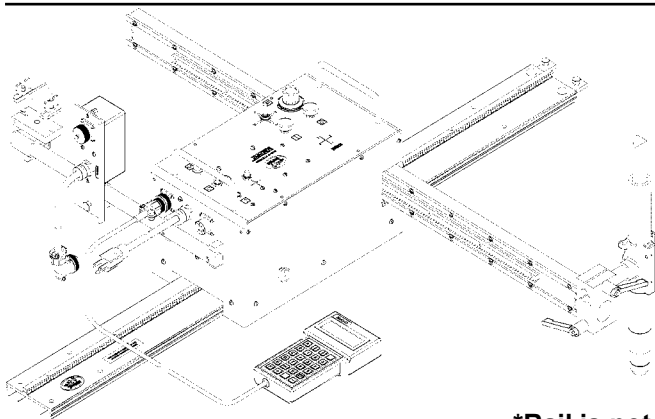

**BUG-6210**     **PROGRAMMABLE SHAPE PLASMA CUTTING KIT 120VAC/50-60/1**

- Includes:**  
 1 BUG-6150-E Programmable Shape Machine and Handheld Terminal.  
                   4-80 ipm (100-2000 mm/min)  
 1 BUG-6080 Relay Box w/Cable Anchor (To control arc on/off)  
 1 BUG-6155 Cutting Group

**BUG-6212**     **PROGRAMMABLE SHAPE MACHINE 240VAC/50-60/1**

**BUG-6214**     **PROGRAMMABLE SHAPE MACHINE 42VAC/50-60/1**

\*Rail is not included with kits.

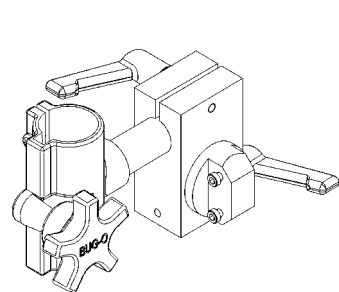

**BUG-6155 Cutting Group**

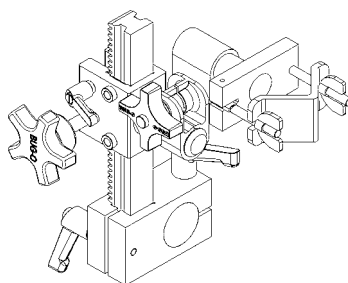

**BUG-6145 Welding Group**

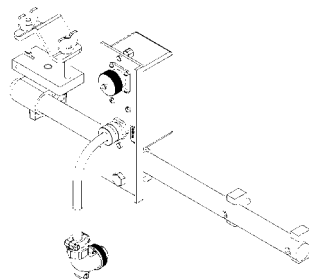

**BUG-6080 Relay Box w/Cable Anchor**

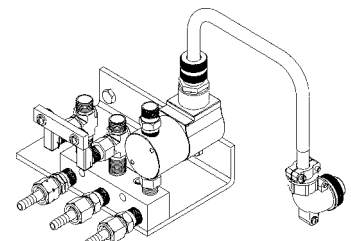

**BUG-6090 Cutting Solenoid Accessory 120VAC**