

INSTRUCTIONS AND PARTS MANUAL

BUG-GY-VERT III VERTICAL FILLET WELDER WITHOUT OSCILLATION

VFW-3350 - 120 VOLT
VFW-3352 - 220 VOLT

Please record your equipment identification information below for future reference. This information can be found on your machine nameplate.

Model Number _____

Serial Number _____

Date of Purchase _____

Whenever you request replacement parts or information on this equipment, always supply the information you have recorded above.

LIT-VFW-WO-IPM-0610



B U G - O S Y S T E M S

A DIVISION OF WELD TOOLING CORPORATION



280 TECHNOLOGY DRIVE CANONSBURG, PENNSYLVANIA USA 15317-9564
PHONE: 1-412-331-1776 <http://www.bugo.com> FAX: 1-412-331-0383

SAFETY

PROTECT YOURSELF AND OTHERS FROM SERIOUS INJURY OR DEATH. KEEP CHILDREN AWAY. BE SURE THAT ALL INSTALLATION, OPERATION, MAINTENANCE AND REPAIR PROCEDURES ARE PERFORMED ONLY BY QUALIFIED INDIVIDUALS.



ELECTRIC SHOCK can kill.

- 1) The equipment is not waterproof. Using the unit in a wet environment may result in serious injury. Do not touch equipment when wet or standing in a wet location.
- 2) The unused connectors have power on them. Always keep the unused connectors covered with the supplied protective panels. Operation of the machine without the protective panels may result in injury.
- 3) Never open the equipment without first unplugging the power cord or serious injury may result.
- 4) Verify the customer-supplied power connections are made in accordance with all applicable local and national electrical safety codes. If none exist, use International Electric Code (IEC) 950.
- 5) Never remove or bypass the equipment power cord ground. Verify the equipment is grounded in accordance with all applicable local and national electrical safety codes. If none exist, use International Electric Code (IEC) 950.

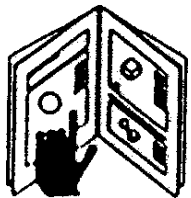

READ INSTRUCTIONS.

Read the instruction manual before installing and using the equipment.



EQUIPMENT DAMAGE POSSIBLE.

- 1) Do not plug in the power cord without first verifying the equipment is OFF and the cord input voltage is the same as required by the machine or serious damage may result.
- 2) Always verify both the pinion and wheels are fully engaged before applying power or equipment damage may occur.
- 3) Do not leave the equipment unattended.
- 4) Remove from the worksite and store in a safe location when not in use.



FALLING EQUIPMENT can cause serious personal injury and equipment damage.

Faulty or careless user installation is possible. As a result, never stand or walk underneath equipment.



MOVING PARTS can cause serious injury.

- 1) Never try to stop the pinion from moving except by removing power or by using the STOP control.
- 2) Do not remove any protective panels, covers or guards and operate equipment.

HIGH FREQUENCY WARNINGS

SPECIAL PRECAUTIONS ARE REQUIRED WHEN USING PLASMA, TIG OR ANY WELDING PROCESS THAT USES HIGH FREQUENCY TO STRIKE AN ARC.



WARNING: HIGH FREQUENCY CAN EFFECT MACHINE OPERATION AND THEREFORE, WELD QUALITY.

Read the precautions below before installing and using the equipment.

PRECAUTIONS:

- 1) Some plasma or welding cables are strong sources of high frequency interference. NEVER lay a plasma or welding cable across the controls of the machine.
- 2) Always physically separate the plasma or welding cable leads from the machine cables. For example, the plasma or welding cable leads should NEVER be bundled with a pendant cable or the machine power cord. Maximize the separation between any machine cables and the plasma or welding cables.
- 3) Strictly follow the grounding procedures specified for the plasma or welding unit. NOTE: Some plasma and welding units produce exceptionally large amounts of high frequency noise. They may require a grounding rod be driven into the earth within six feet (2 meters) of the plasma or welding unit to become compatible with an automatic cutting or welding process.
- 4) If the high frequency is produced using a spark gap, adjust the points so the gap is as small as possible. The larger the gap, the higher the voltage and the higher the interference.
- 5) Some plasma or welding units will inject high frequency interference into the AC power line. Use separate power line branches whenever possible to power the plasma or welding source and the machine. Do not plug them into the same outlet box.
- 6) High frequency noise may enter the machine through the plasma or welding supply remote contactor leads. Some plasma and welding sources can produce noise spikes of up to several thousand volts. These sources are not compatible with automated cutting and welding equipment. It is recommended that the remote contactor leads on these plasma or welding sources not be connected to the machine. An alternate solution is to purchase a separate remote contactor isolation box.

BUG-GY-VERT III

VERTICAL FILLET WELDER

INSTRUCTIONS AND PARTS MANUAL

TABLE OF CONTENTS

2	SAFETY
3	HIGH FREQUENCY WARNINGS
5	INTRODUCTION
5	FEATURES
6	MACHINE SETUP
7	CARRIAGE CONTROLS
7	WELDING
8	TECHNICAL DATA
8	DIMENSIONS
10	VFW-3350 BUG-GY-VERT III / EXPLODED VIEW / PARTS LIST
11	VFW-3352 BUG-GY-VERT III / WIRING DIAGRAM / ELECTRICAL COMPONENT CHART
11	ELECTRICAL COMPONENT CHART
12	ZSP-0365-01-00-00-0 DRIVE SYSTEM / PARTS LIST
13	ZSP-0365-01-00-00-0 DRIVE SYSTEM / EXPLODED VIEW
14	C07182-330-70-01 MAGNET ASSEMBLY / PARTS LIST / EXPLODED VIEW
15	ZSP-0365-02-00-00-0 MAIN MOTOR ASSEMBLY / PARTS LIST / EXPLODED VIEW
16	ZSP-0365-02-01-00-0 ELECTRONIC CONTROL SYSTEM / PARTS LIST / EXPLODED VIEW
17	PNL-0365-02-01-20-0 MAIN MOTOR PANEL ASSEMBLY / PARTS LIST / EXPLODED VIEW
18	ZSP-0365-02-02-00-0 POWER SUPPLY ASSEMBLY / PARTS LIST / EXPLODED VIEW
19	C07182-330-90-00 CABLE ANCHOR ASSEMBLY / PARTS LIST / EXPLODED VIEW
20	C07182-500-70-00 ADJUSTMENT MECHANISM / PARTS LIST / EXPLODED VIEW
21	UCW-0246-05-00-00-1 TORCH HOLDING ASSEMBLY / PARTS LIST / EXPLODED VIEW
22	W07507-251-00-01 TILTED GUIDE RF-2 ASSY / PARTS LIST / EXPLODED VIEW
23	WARRANTY
23	HOW TO OBTAIN SERVICE

INTRODUCTION:

The BUG-GY-VERT III is a portable battery powered 4-wheel drive welding carriage. Strong permanent magnets hold the machine on the work piece allowing it to travel on vertical or oblique work surfaces. Guide wheels on the BUG-GY-VERT III automatically track the torch in the fillet joint. The BUG-GY-VERT III is compact, lightweight and easy to position. It will accommodate most hand held welding guns. By providing consistent travel speed and path the BUG-GY-VERT III can increase the productivity and the quality by producing uniform, consistent welds.

FEATURES:

- Lightweight, easy to carry design.
- Permanent magnet for powerful traction.
- Equipped with a four-wheel drive carriage.
- Built-in weld contactor connection.
- Dynamic braking for crisp starts and stops.
- Closed loop speed & position control.
- 3 to 50 ipm (75-1270 mm/min) welding speed range.
- 14.4-volt rechargeable battery with battery charger.
- Spatter guard on work-side wheels.
- Versatile quick disconnect gun clamp will fit most MIG guns.
- Precision micro-adjustable “Y” & “Z” slides for gun positioning.
- Available in two operating voltages: 110 & 220 VAC.

MACHINE SETUP:

1. Remove the machine from the shipping box. Be sure to account for all loose parts before discarding the box!
2. Place the **Battery** in the charger, (which is included) and connect to 220/50/1 or 110/50-50/1 power outlet (depending on the model you have). Let the **Battery** charge for 2-3 hours. The light on the charger will “blink” while it is charging. When the light stays “on” the **Battery** is fully charged and ready for use.
3. Place the **Battery** on the BUG-GY-VERT III. When the **Battery** becomes “low”, the light on the machine will “blink”. When the light starts blinking, the **Battery** must be removed and recharged.
4. Install the **Follower Arms** at each end of the machine. The **Follower Arm** in the “Front” (the direction of travel) must always be set a 1/2” (12 mm) “Shorter” than the trailing arm. This directs the machine to track toward the opposed wall to keep the torch in position.
5. Install the **Cable Anchor Assembly** to the machine as shown.
6. Mount the welding torch in the **Quick Disconnect Clamp** and position the torch in the joint using the **Cross Slides**. Position the wire feed cable in the **Cable Anchor Assembly** to prevent drag.

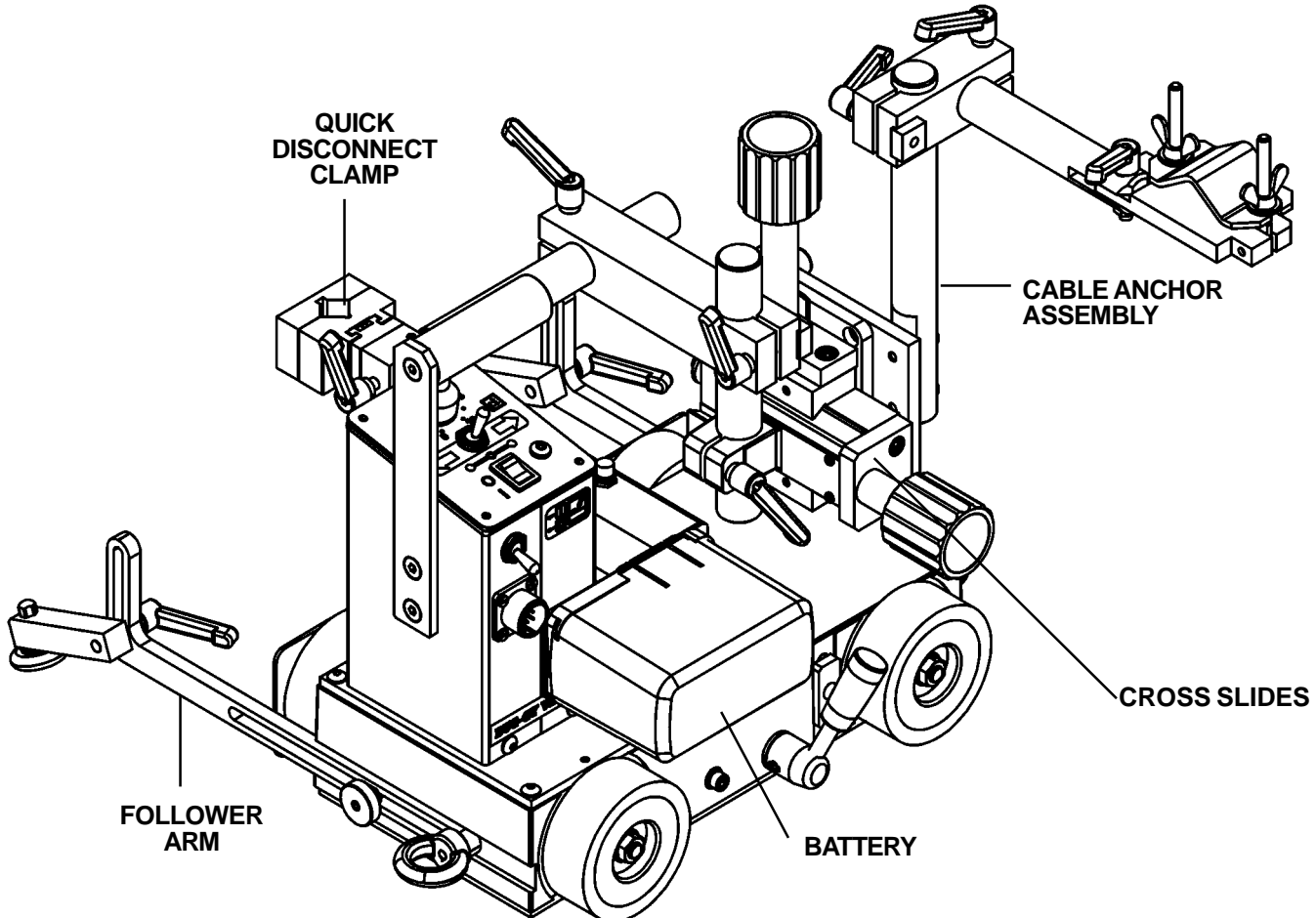

CARRIAGE CONTROLS:

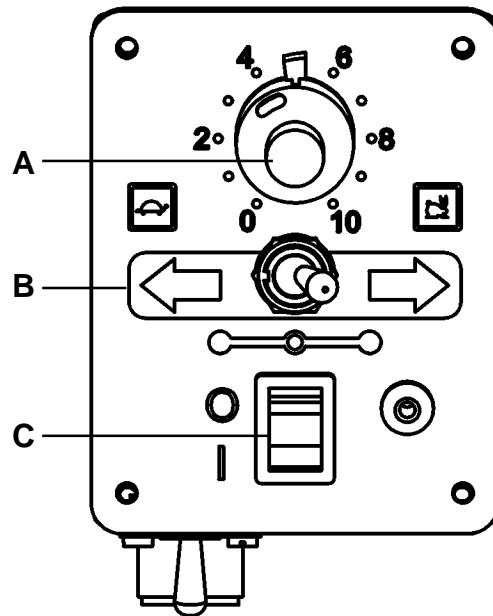
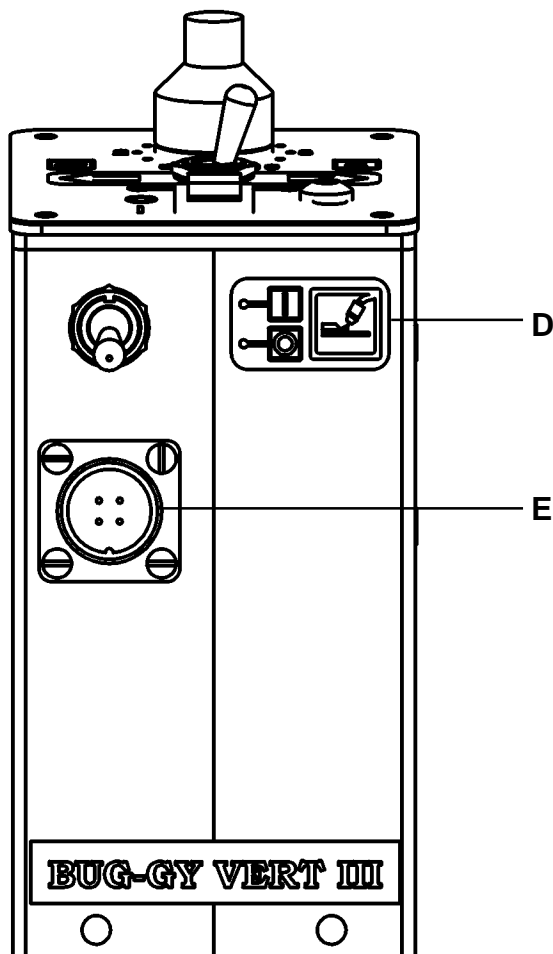

- A. Travel Speed Control
- B. Travel Direction “Forward/Stop/Reverse” Switch
- C. Power On/Off Switch
- D. Arc Enable On/Off Switch
- E. Weld Contactor Plug

WELDING:

1. Toggle the **Power On/Off Switch (C)** to the “**On**” position.
2. Toggle the **Travel Direction Switch (B)** to set the direction of travel.
3. Regulate the speed of travel by rotating the **Travel Speed Knob (A)**, counter-clockwise will decrease the speed of the machine while clockwise will increase the speed of the machine.
4. Connect the welding torch “trigger switch leads” to the **Weld Contactor Plug (E)**, so the wire feeder will be turned “**On/Off**” automatically when the **Travel Direction Switch (B)** is thrown “**Left/Right**”.
5. To weld, stop the machine by toggling the **Travel Direction Switch (B)** to the “**Stop**” position, switch the **Arc Enable On/Off Switch (D)** to the “**On**” position, and toggle the **Travel Direction Switch (B)** corresponding to the correct direction of travel.
6. Travel speed and torch position may be adjusted during the welding operation.
7. To stop welding, toggle the **Travel Direction Switch (B)** to the “**Stop**” position.

CAUTION: CONNECT A SAFETY LINE TO THE TOP OF THE MACHINE BEFORE WELDING IN THE VERTICAL POSITION. The welding cable should be supported beside the machine, to reduce the load on the machine.

TECHNICAL DATA:

Power Requirements: VFW-3350 110 VAC Includes 1 battery and 1 charger
VFW-3352 240 VAC Includes 1 battery and 1 charger

Power Supply: 14.4 Volt rechargeable battery

Travel Modes: Continuous in all positions.

Travel Speed: Welding 3-50 ipm (75-1270 mm/min)

Net Weight: 28 lbs. (14 kg)

Shipping Weight: 35 lbs. (16 kg)

NOTE: The recommended minimum plate thickness for vertical welds is 1/4" (6.35 mm)

DIMENSIONS:

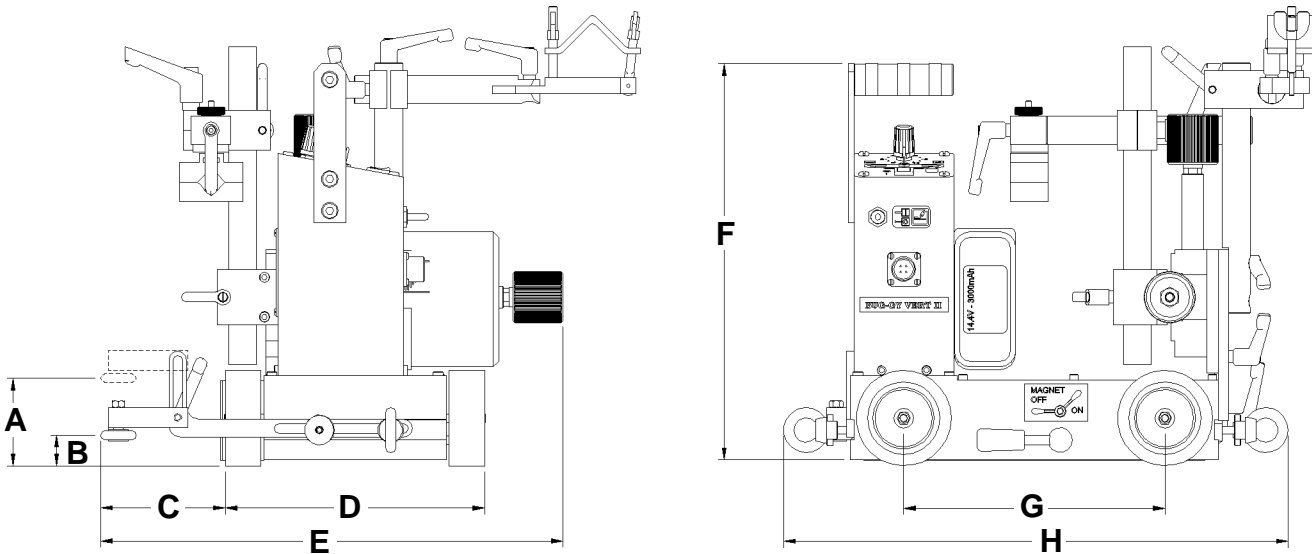

A	1.250 in	(32 mm)
B	0.50 in	(13 mm)
C	3 - 6.5 in	(76 - 116 mm)
D	8.125 in	(206 mm)
E	13.188 - 16.688 in	(335 - 424 mm)

F	12.625 in	(321 mm)
G	8.188 in	(208 mm)
H	16.250 in	(413 mm)

This page intentionally left blank

VFW-3350 BUG-GY-VERT III / EXPLODED VIEW / PARTS LIST

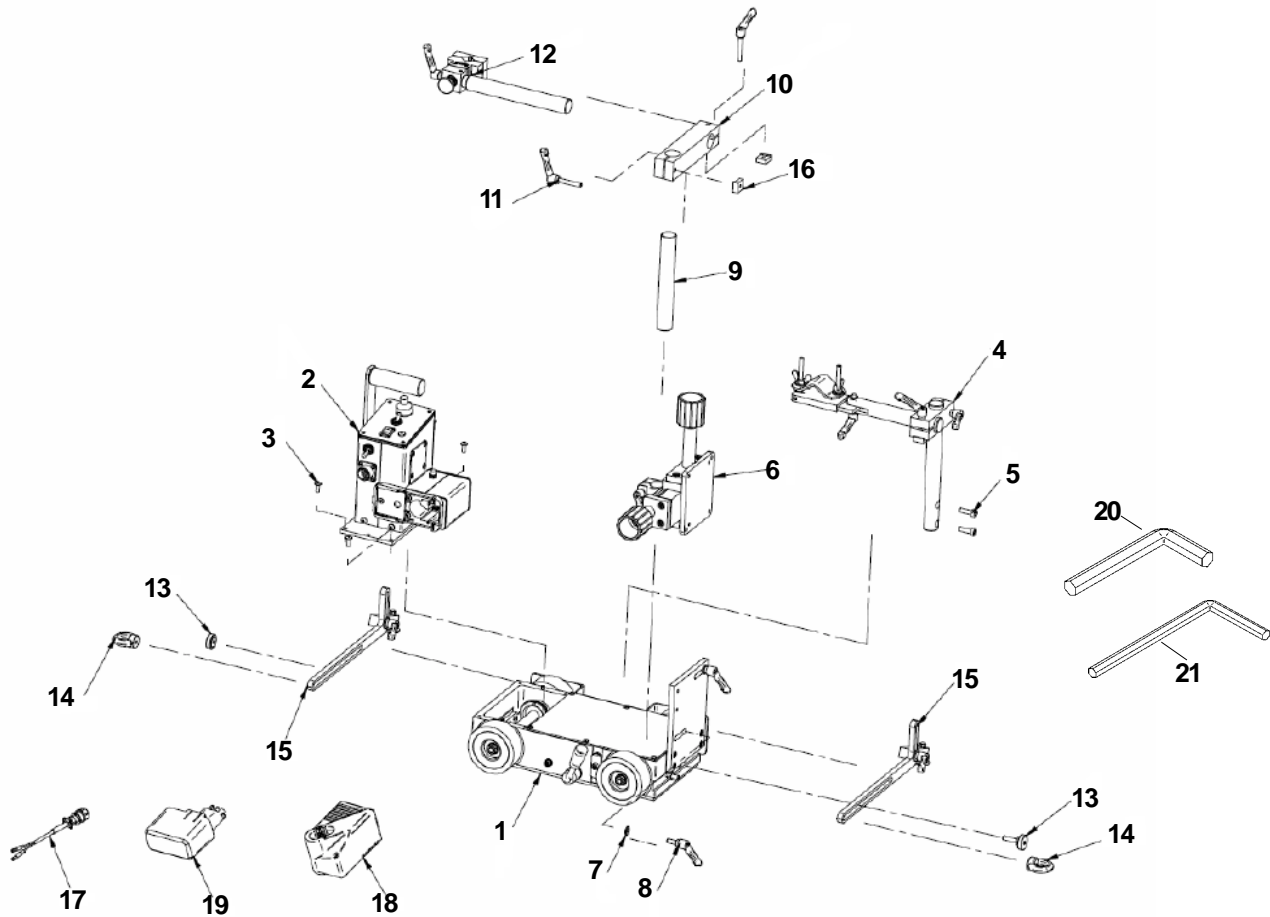

ITEM	QTY	PART NUMBER	DESCRIPTION
1	1	ZSP-0365-01-00-00-0	Drive System
2	1	ZSP-0365-02-00-00-0	Main Motor Assembly
3	4	WKR-000098	Screw, But Hd Soc M5 x 16
4	1	C07182-330-90-00	Cable Anchor Assembly
5	2	N18230-206-20-01	Hex Socket Bolt M6 x 20
6	1	C07182-500-70-00	Adjustment Mechanism
7	2	N18200-606-04-02	Round Washer 6.4
8	2	H00643-480-01-02	Handlever M6-16
9	1	SLP-0233-13-02-00-0	Vertical Rod
10	1	KST-0233-13-01-00-0	Torch Holding Housing
11	2	H00643-480-01-01	Handlever, M6-32
12	1	UCW-0246-05-00-00-1	Torch Holding Assembly
13	2	WKR-0250-01-03-00-0	Knurled Thumb Screw M6x35
14	2	C07182-330-12-60	Eye Bolt
15	2	W07507-251-00-01	Tilted Guide RF-2 Assy
16	2	NKR-0261-03-05-00-0	Square Nut
17	1	WZK-0250-00-02-00-0	4-Pin Plug with (2) Wires
*18	1	H01113-001-01-03	Charger - 110V
19	1	H01134-001-01-02	Battery
20	1	H00643-505-01-00	Hex Wrench S=5
21	1	H00643-502-01-00	Hex Wrench S=2.5

*H01113-001-01-02 Charger - 220V

VFW-3350 BUG-GY-VERT III / WIRING DIAGRAM / ELECTRICAL COMPONENT CHART

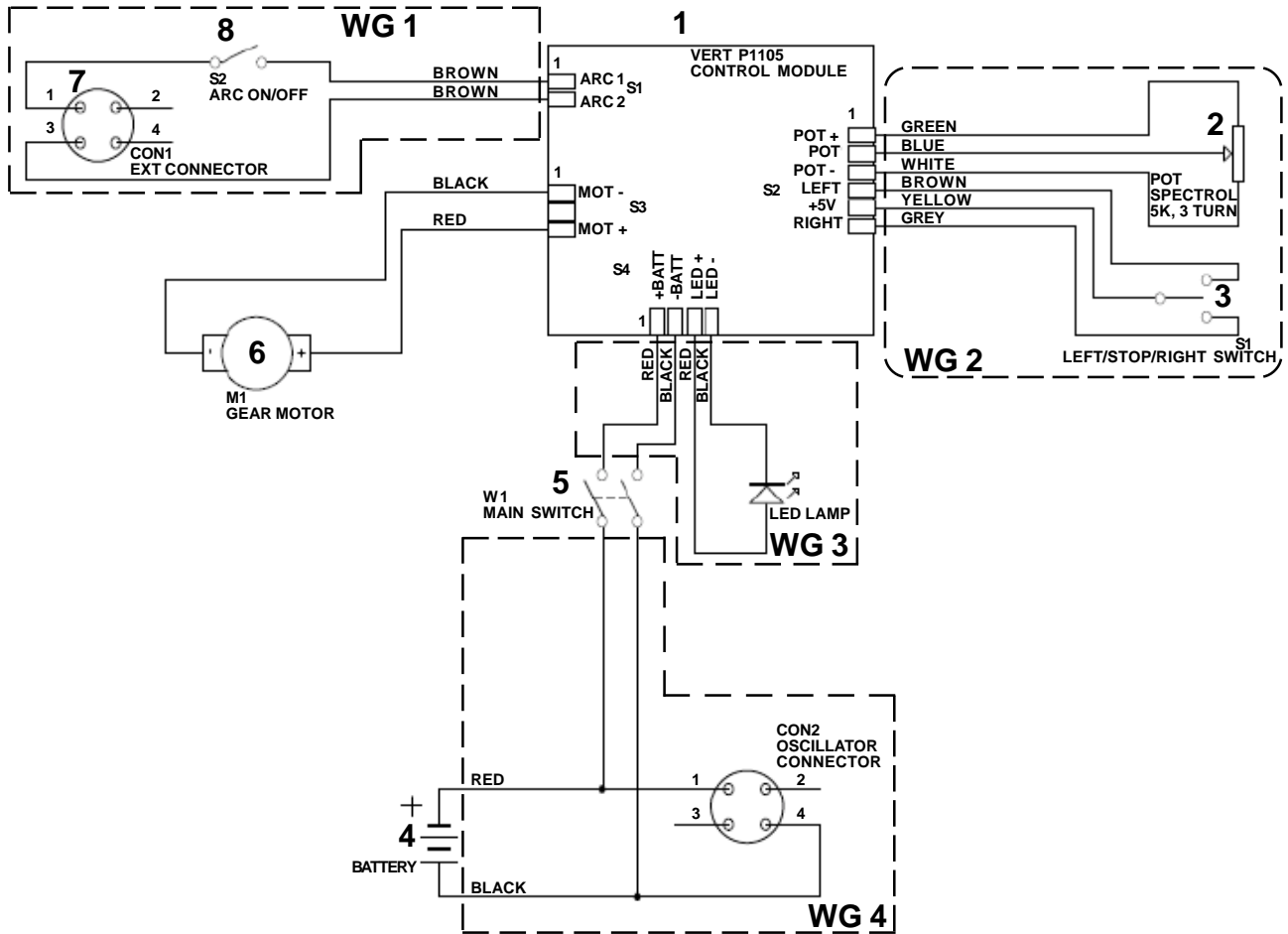

ELECTRICAL COMPONENT CHART

ITEM	QTY	DESCRIPTION	PART NUMBER
1	1	Electronic Controller	STR-0250-06-06-00-1
2	1	Potentiometer	PTN-000026
3	1	Switch (3 position)	PNK-000001
4	1	Battery	H01134-001-01-02
5	1	Switch	H01115-170-01-01
6	1	Motor	SLN-0365-02-04-00-0
7	1	Panel Connector	H01131-002-01-02
8	1	Toggle Switch (2 pos.)	H01115-174-01-00
WG1	1	Weld Contactor Wires (Includes 7 & 8)	C07182-330-60-61
WG2	1	Speed & Direction Wires (Includes 2 & 3)	WZK-0365-02-01-40-0
WG3	1	LED Ass'y	C07182-330-60-70
WG4	1	Coupling w/ Wires	C07182-330-13-31

ZSP-0365-01-00-00-0 DRIVE SYSTEM / PARTS LIST

ITEM	QTY	PART NUMBER	DESCRIPTION
1	1	KRP-0365-01-02-00-0	Frame Assembly
2	1	C07182-330-10-20	Drive Shaft I
3	1	C07182-330-10-30	Drive Shaft II
4	1	C07182-330-10-60	Bevel Gear
5	2	C07182-330-10-70	Pulley
6	1	C07182-330-10-80	Spring 1.2 x 20 x 42.5
7	1	C07182-330-10-90	Tension Plate
8	2	C07182-330-11-00	Tension Shaft I
9	2	C07182-330-11-20	Tension Sleeve
10	1	C07182-500-10-10	Guard Plate
11	1	C07182-330-11-40	Plate
12	1	C07182-330-11-50	Cam Shaft
13	2	C07182-330-11-60	Cam
14	1	GLK-0365-01-01-00-0	Handle Knob
15	2	C07182-330-11-91	Magnet Plate, Small
16	5	C07182-330-12-10	Distance Washer
17	2	C07182-330-12-20	Washer Din 433
18	1	C07182-330-12-30	Washer
19	1	C07182-330-12-40	Guard
20	4	C07182-331-10-00	Drive Wheel
21	1	C07182-330-11-80	Handle
22	1	C07182-330-12-70	Sleeve Bearing 9 x 16 x 10
23	1	C07182-330-12-80	Sleeve Bearing 12 x 16 x 10
24	2	N18511-120-28-00	Internal Retaining Ring 28W
25	2	N18230-205-20-02	Hex Socket Bolt M5 x 20
26	6	N60738-004-10-02	Screw M4 x 10
27	2	N18230-204-10-00	Hex Socket Bolt M4 x 10
28	4	N60738-005-10-02	Screw M5 x 10
29	6	N18230-205-12-00	Hex Socket Bolt M5 x 12
30	5	N60799-105-12-02	Scr M5 x 12 FHSCS
31	3	N18231-605-12-02	Socket Set Screw M5x12
32	1	N60091-306-06-10	SSS M6 x 6-8.8 Flat Point
33	1	N18200-605-03-00	Round Washer 5.3
34	4	N18200-608-04-01	Round Washer 8.4
35	4	N18215-308-00-01	Hex Nut M8 (Short)
36	2	N18502-304-16-00	Spring Pin 4x16
37	2	N18502-104-12-00	Pin 4x12
38	2	N18511-110-10-00	External Retaining Ring 10z
39	4	H00636-300-01-15	Bearing 6001 ZZ
40	1	H01374-001-01-03	Belt 210xL050
41	1	H01262-005-01-06	Oval Knob
42	2	H01362-002-01-06	Slide Sleeve 12x18x16
43	6	H01158-333-01-02	Magnet
44	1	C07182-330-70-01	Magnet Assembly
45	2	N60799-105-16-02	SCREW, M5x16
46	1	C07182-330-12-90	Label "Magnet" (not shown)
47	1	C07182-330-13-20	Power Wires I (not shown)

ZSP-0365-01-00-00-0 DRIVE SYSTEM / EXPLODED VIEW

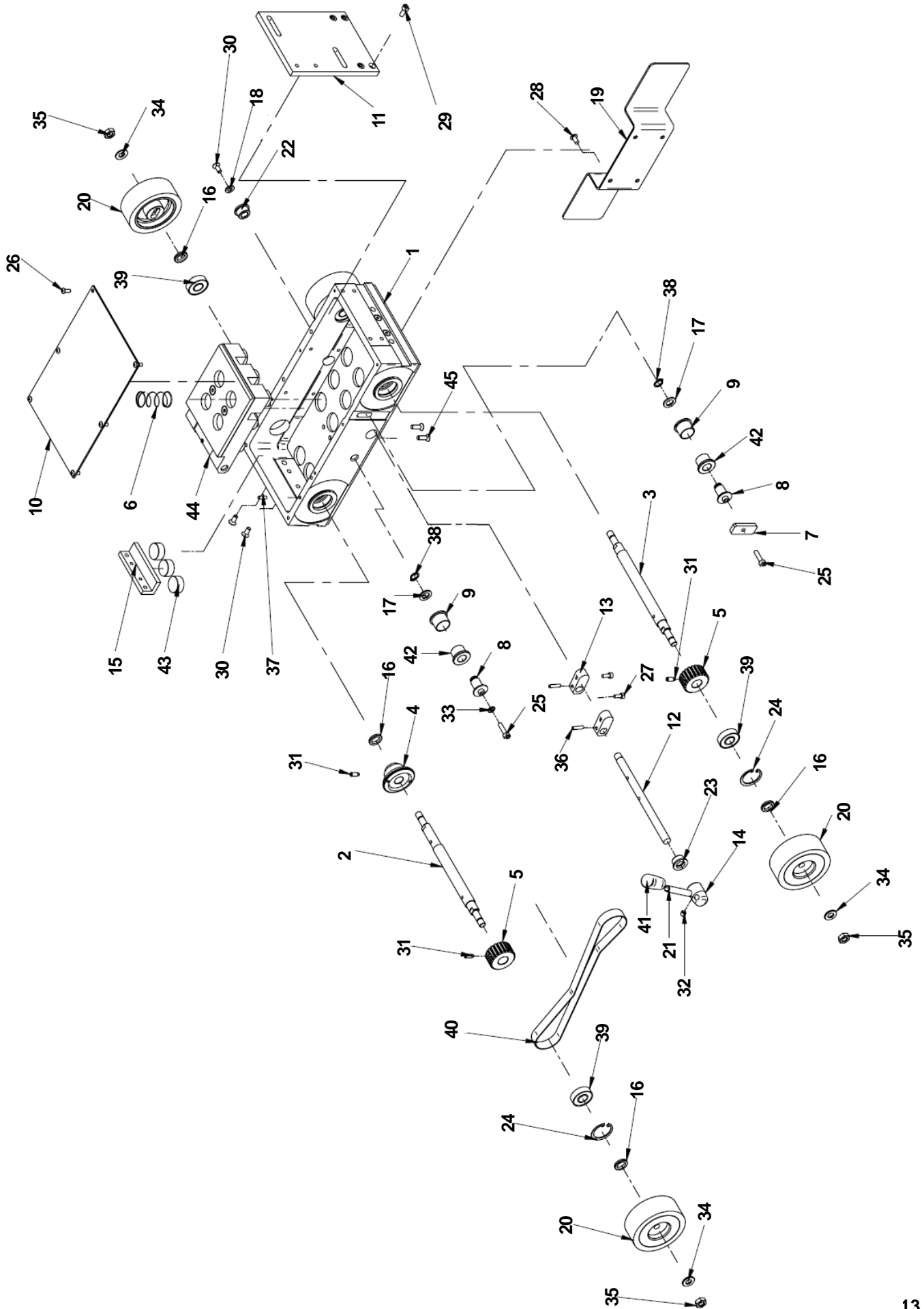

C07182-330-70-01 MAGNET ASSEMBLY / PARTS LIST / EXPLODED VIEW

ITEM	QTY	PART NUMBER	DESCRIPTION
1	1	C07182-330-70-10	Magnet Frame
2	1	C07182-330-70-20	Magnet Plate
3	1	C07182-330-70-31	Mounting
4	1	C07182-330-70-40	Mounting Shaft
5	1	N60799-106-20-02	Screw M6 x 20 FHSCS
6	1	N60799-106-12-02	Screw M6 x 12 FHSCS
7	1	N60091-305-06-00	Socket Set Screw M5 x 6
8	27	H01158-333-01-02	Magnet 22x10
9	1	C07182-330-70-50	Cam Buffer

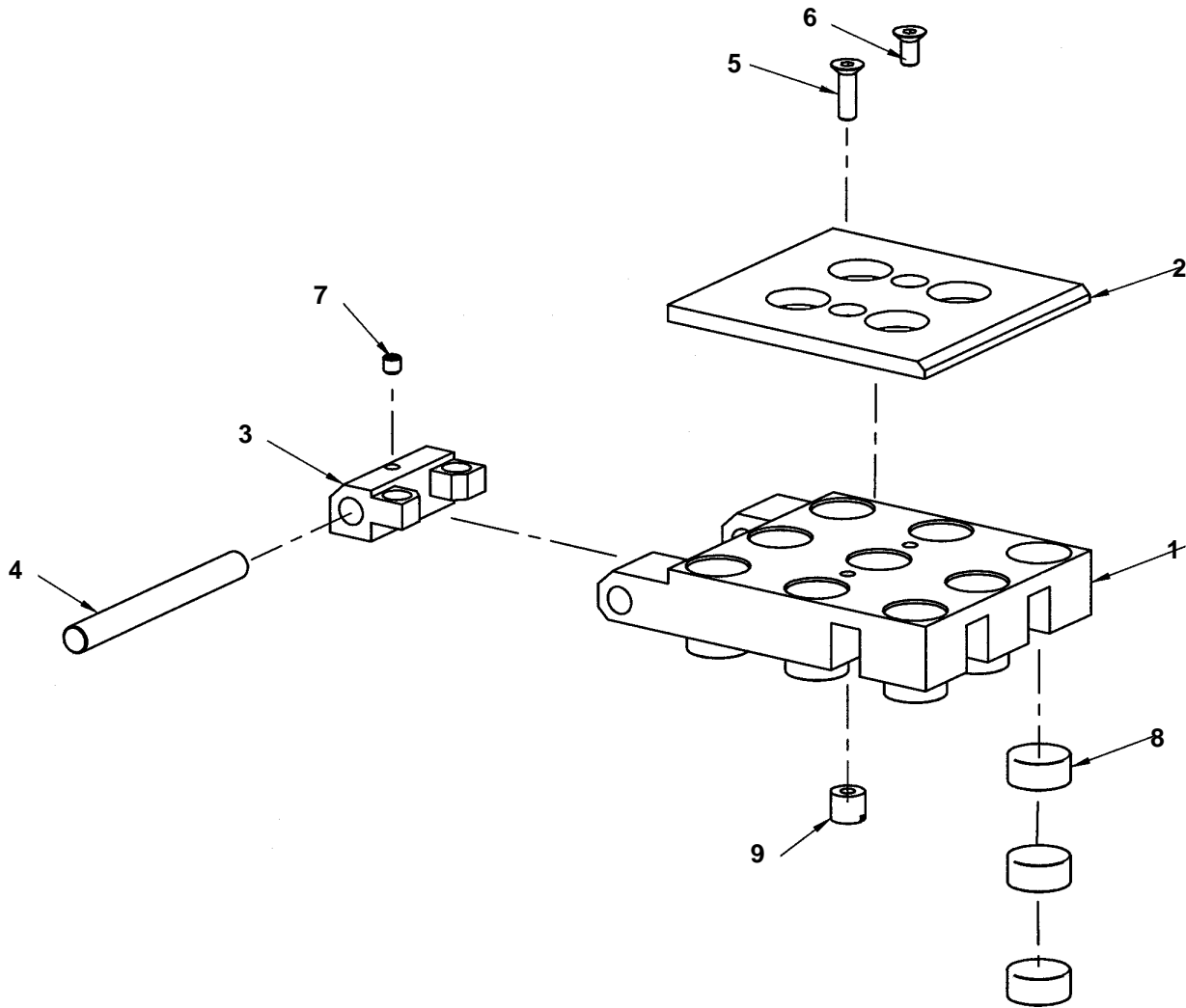

ZSP-0365-02-00-00-0 MAIN MOTOR ASSEMBLY / PARTS LIST / EXPLODED VIEW

ITEM	QTY	PART NUMBER	DESCRIPTION
1	1	KRP-0365-02-03-00-0	Motor Frame
2	1	C07182-500-50-20	Bevel Gear
3	1	C07182-330-50-40	Motor Plate
4	1	ZSP-0365-02-01-00-0	Electronic Control System
5	1	SLN-0365-02-04-00-0	Main Motor Assy
6	4	N60738-005-12-02	Screw, But Hd Soc M5x12
7	4	N60799-105-16-02	Screw, Flt Hd Soc M5 x 16
8	1	N18511-120-08-00	Internal Retaining Ring 8W
9	1	N60091-305-05-00	Screw M5 x 5
10	4	WKR-000132	Screw, Flt Hd Soc M4 x 16
11	4	N60738-004-10-02	Screw, But Hd Soc M4 x 10
12	1	ZSP-0365-02-02-00-0	Power Supply Assembly

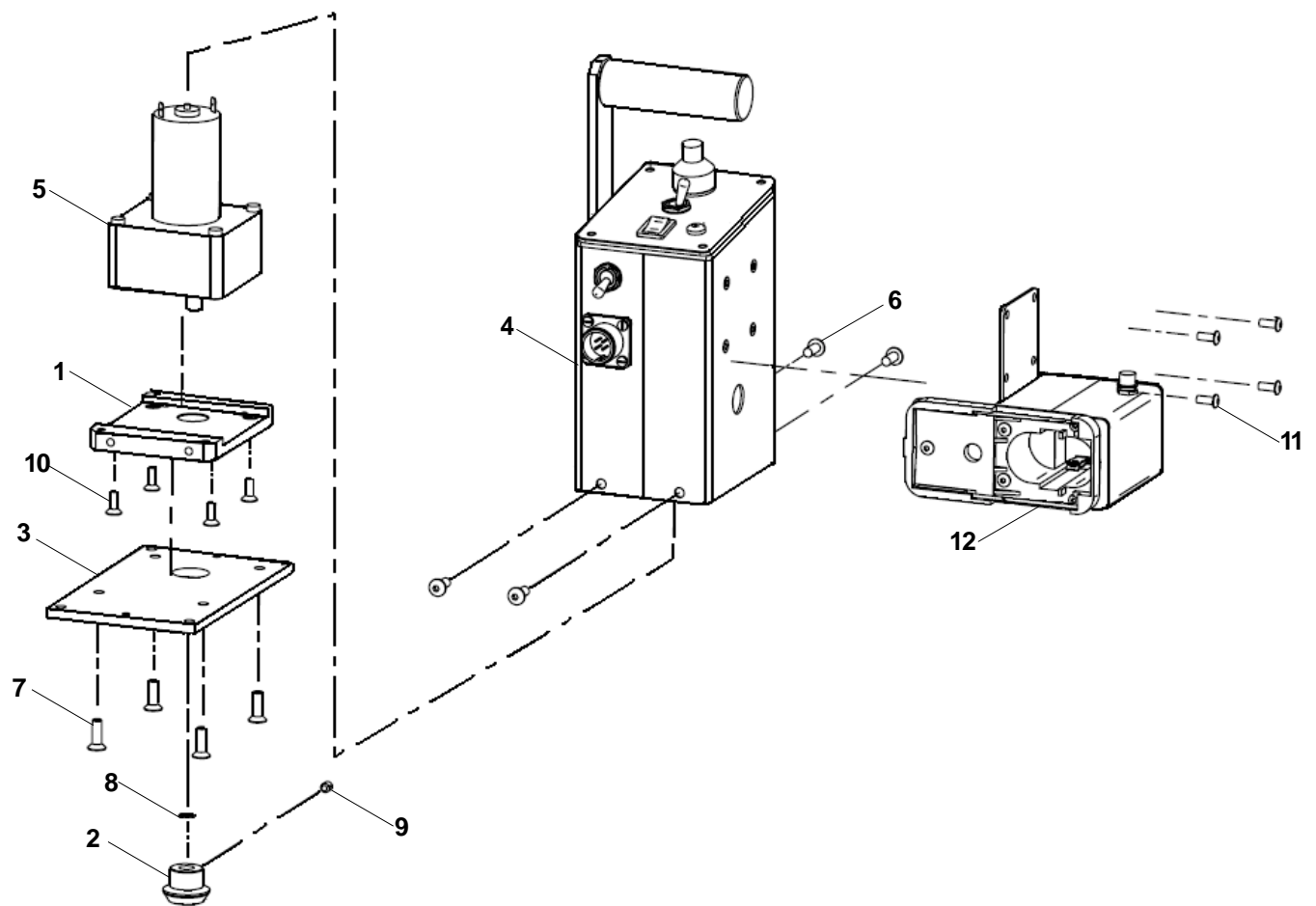

ZSP-0365-02-01-00-0 ELECTRONIC CONTROL SYSTEM / PARTS LIST / EXPLODED VIEW

ITEM	QTY	PART NUMBER	DESCRIPTION
1	1	OBD-0365-02-01-10-0	Electronic Controller Housing
2	1	PNL-0365-02-01-20-0	Main Motor Panel Ass'y
3	4	N60738-004-10-02	Screw, But Hd Soc M4 x 10
4	1	C07182-330-60-61	Coupling Assembly (includes 5 & 6)
5	1	H01115-174-01-00	Toggle Switch
6	1	H01131-002-01-02	Coupling, 4-T, M
7	4	WKR-000182	Screw, M3 x 8
8	1	C07182-500-60-20	Holder Bracket
9	1	C07182-330-12-50	Holder
10	2	N60799-106-16-02	Screw, Flt Hd Soc M6 x 16
11	1	N60799-106-20-02	Screw, Flt Hd Soc M6 x 20

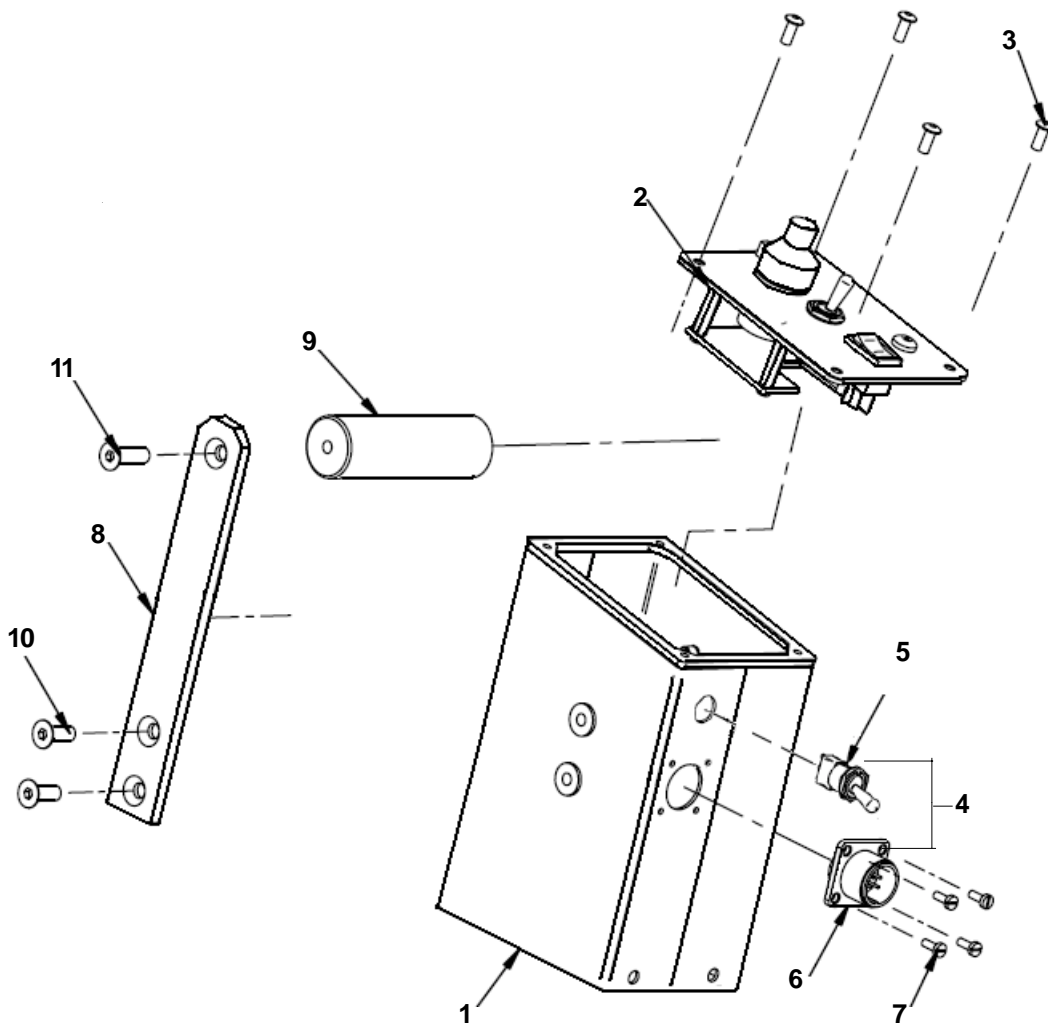

PNL-0365-02-01-20-0 MAIN MOTOR PANEL ASSEMBLY / PARTS LIST / EXPLODED VIEW

ITEM	QTY	PART NUMBER	DESCRIPTION
1	1	MSK-0365-02-01-30-0	Panel Plate Ass'y
2	1	STR-0250-06-06-00-1	Electronic Controller
3	1	PKT-000026	Potentiometer Handwheel
4	1	WZK-0365-02-01-40-0	Lever Switch Ass'y (Includes 5 & 6)
5	1	PTN-000026	Potentiometer, 5K ohm
6	1	PNK-000001	Lever Switch, 3 position
7	1	H01156-114-01-01	LED Socket
8	1	H01115-170-01-01	Switch
9	4	N18220-703-06-00	Screw, M3 x 6
10	1	C07182-330-60-70	LED Ass'y
11	4	N18202-403-02-01	Lock Washer, Internal Star M3
12	1	C07182-330-60-30	Label (Not Shown)

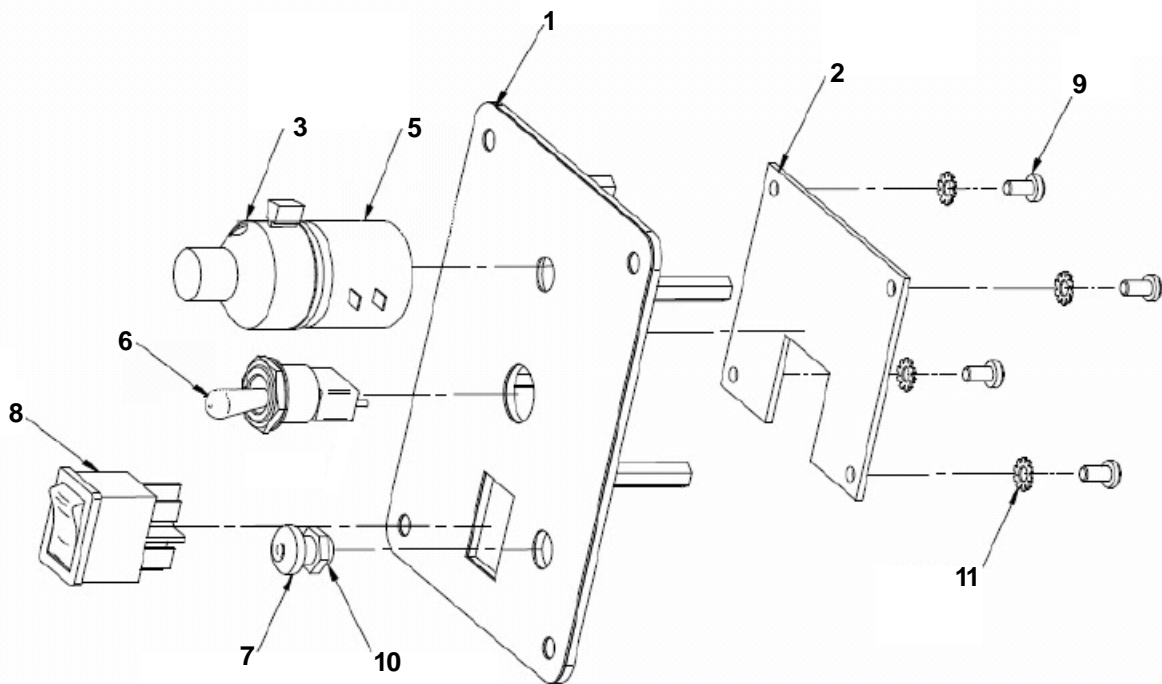

ZSP-0365-02-02-00-0 POWER SUPPLY ASSEMBLY / PARTS LIST / EXPLODED VIEW

ITEM	QTY	PART NUMBER	DESCRIPTION
1	1	C07182-460-70-10	Contacts Socket
2	1	KRP-0365-02-02-10-0	Contacts Housing
3	1	C07182-500-30-20	Cover
4	2	C07182-500-30-30	Contacts Long
5	2	C07182-500-30-40	Contacts Short
6	1	C07182-500-30-50	Catch
7	4	N18220-203-08-01	Screw, Cross Recessed M3 x 8
8	3	N60738-004-10-02	Screw, But Hd Soc M4 x 10
9	2	N18215-103-00-00	Square Nut
10	1	H01370-001-01-06	Snap Bushing LA6
11	1	C07182-500-30-80	Spring Blocking
12	6	WKR-000182	Screw, But Hd Soc M3x 8
13	1	C07182-330-13-31	Power Wires

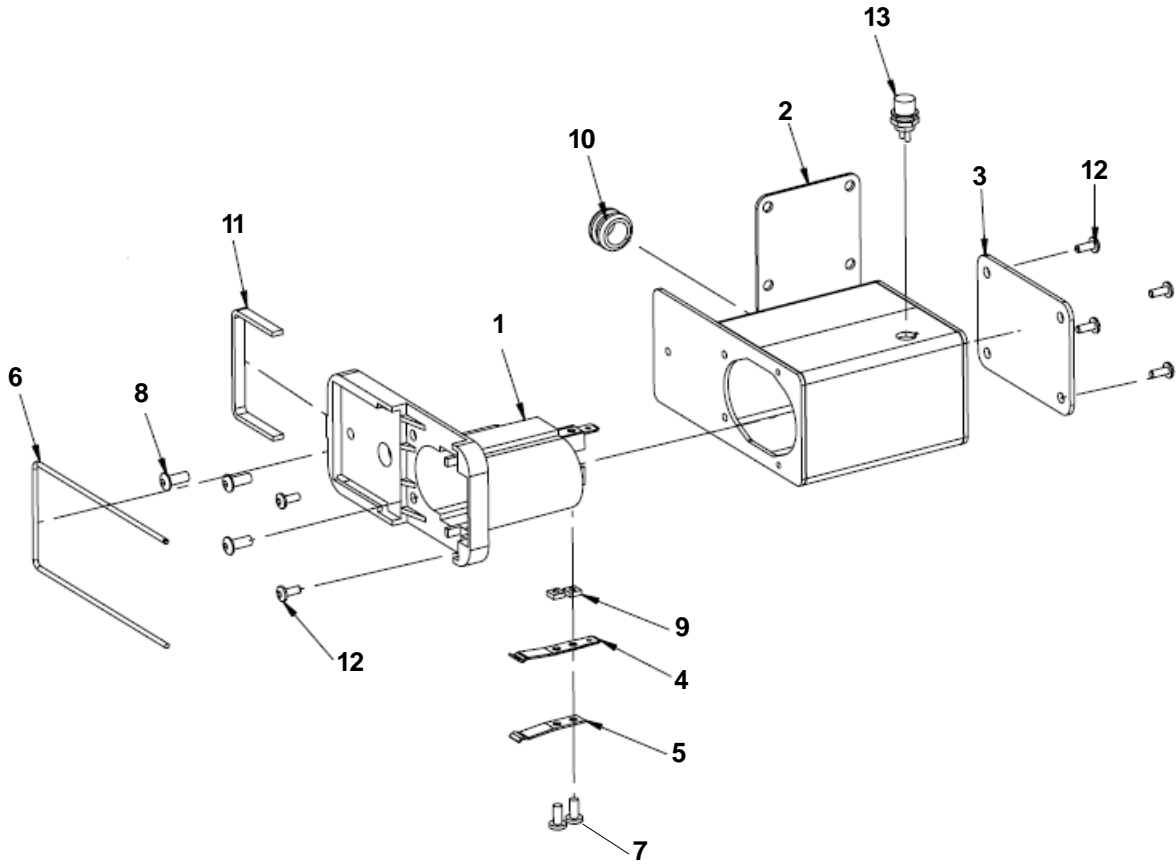

C07182-330-90-00 CABLE ANCHOR ASSEMBLY / PARTS LIST / EXPLODED VIEW

ITEM	QTY	PART NUMBER	DESCRIPTION
1	1	C07182-330-90-10	Cable Holding Vertical
2	1	C07182-210-50-20	Cable Holding Housing
3	1	C07182-330-20-80	Guide Bar
4	1	C07182-190-61-60	Clamp Plate I
5	1	C07182-190-61-50	Clamp Plate II
6	1	C07181-800-02-60	Clamp Bolt
7	1	C07181-800-02-70	Stud Bolt
8	1	H00643-480-01-00	Hand Lever M6-25
9	2	H00643-480-01-05	Hand Lever M6-35
10	1	N18214-406-00-01	Hex Nut M6
11	2	N18243-906-00-00	Wing Nut M6
12	1	KLK-000015	Spring Pin 4 x 26
13	2	N18200-606-04-01	Round Washer 6.4
14	2	NKR-0261-03-05-00-0	Square Nut

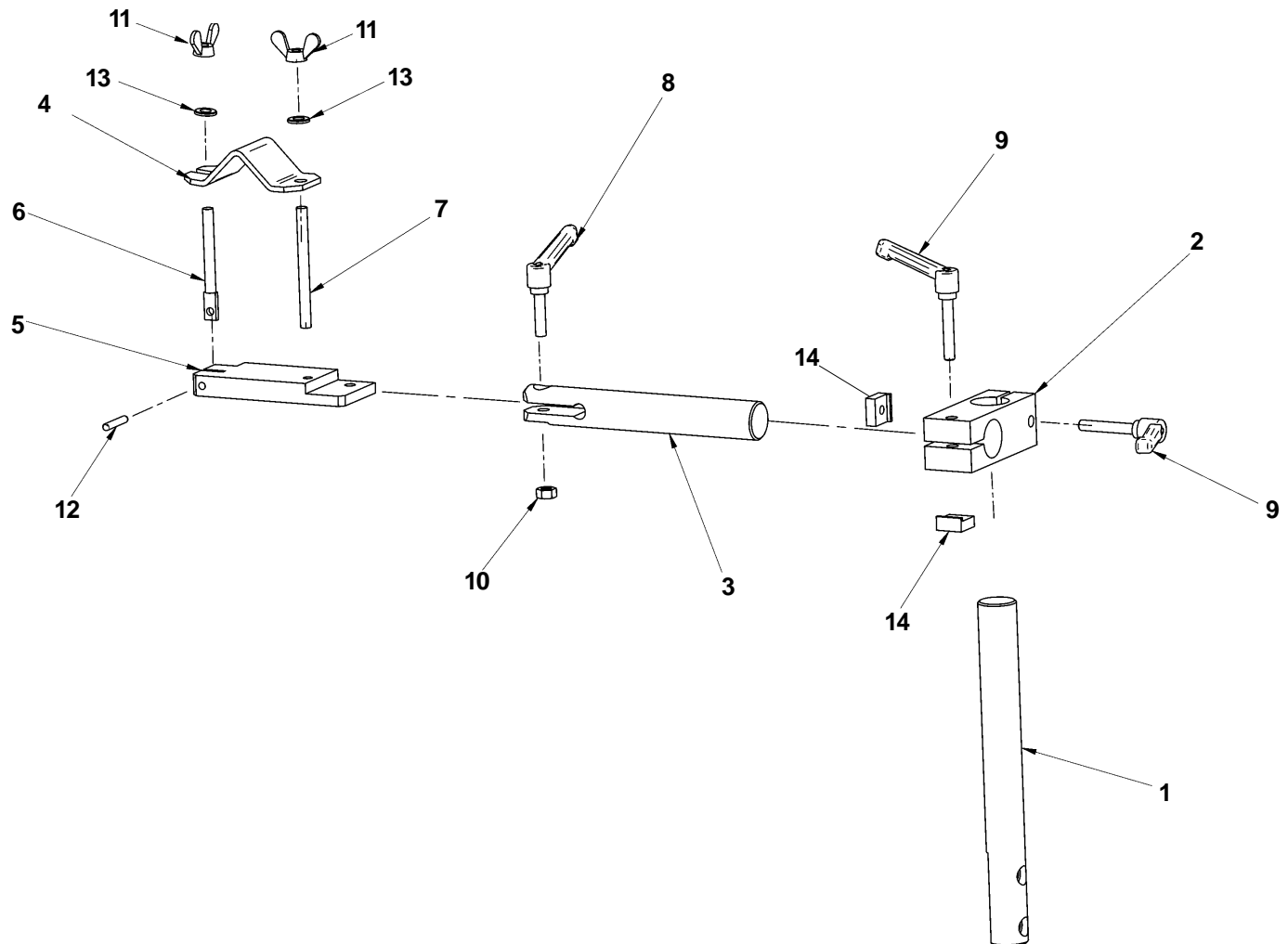

C07182-500-70-00 ADJUSTMENT MECHANISM / PARTS LIST / EXPLODED VIEW

ITEM	QTY	PART NUMBER	DESCRIPTION
1	1	C07182-190-60-13	Housing
2	1	C07182-190-60-22	Vertical Guide
3	1	C07182-190-60-31	Horizontal Guide
4	1	C07182-190-60-50	Horizontal Guide Screw
5	1	C07182-190-60-60	Vertical Cover Plate
6	1	C07182-190-61-10	Horizontal Sleeve
7	8	C07182-190-61-20	Disk
8	8	C07182-190-61-30	Slipper
9	1	C07182-330-80-20	Horizontal Cover Plate
10	1	C07182-330-80-30	Sleeve
11	1	C07182-330-80-40	Guide Screw
12	2	C07182-330-80-50	Hand Wheel
13	1	H00643-480-01-01	Handlever, M6-32
14	2	H01262-015-01-02	Special Round Washer
15	2	N18200-606-04-01	Round Washer 6.4
16	2	N18201-905-05-01	Round Washer A5.5
17	2	N18214-408-00-01	Hex Nut M8
18	6	N18230-205-14-00	Hex Socket Bolt M5 x 14
19	4	N60091-305-12-00	Set Screw M5 x 12
20	4	N60091-305-20-02	Set Screw M5 x 20
21	16	N60209-342-10-05	Disc Spring 4.2 x 10x 0.5
22	4	N60209-382-18-07	Disc Spring 8.2 x 18x 0.7

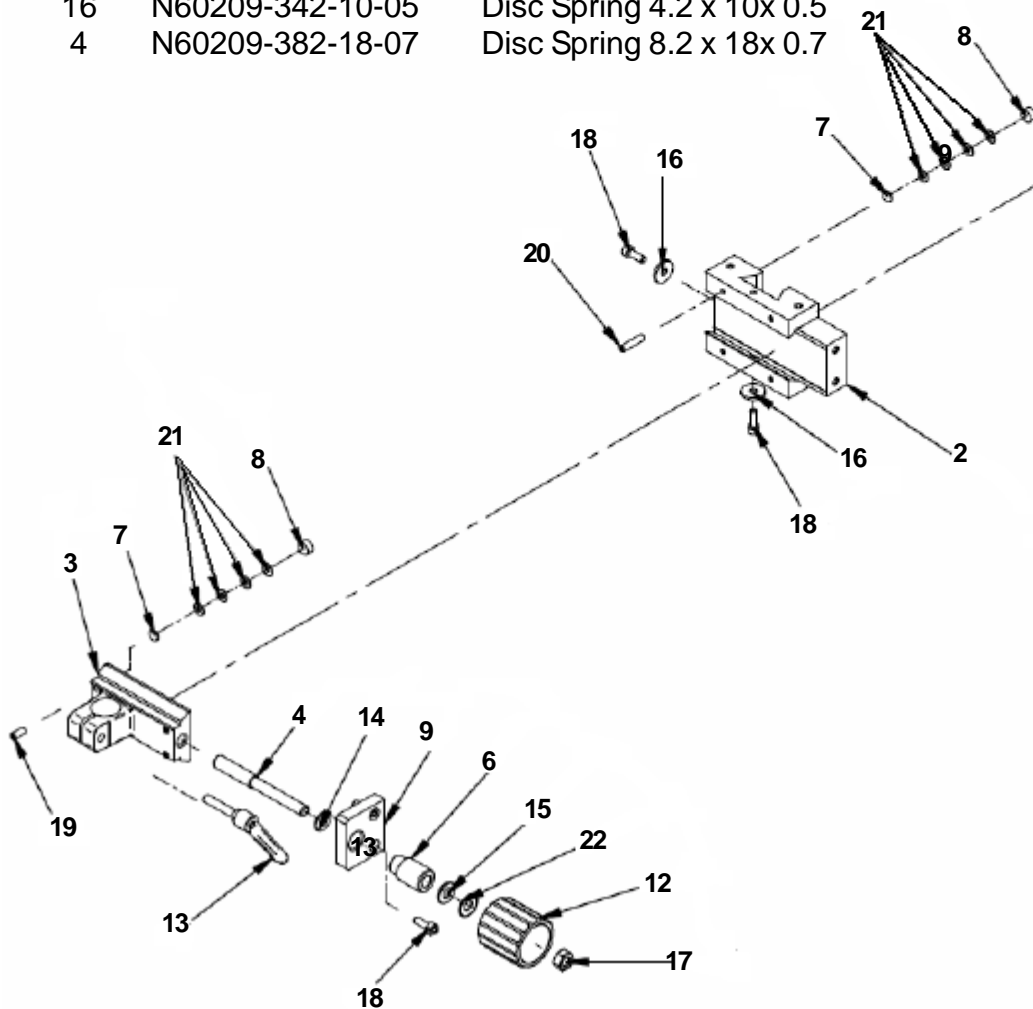
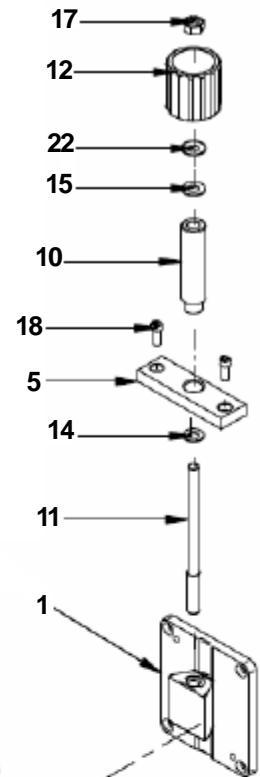

UCW-0246-05-00-00-1 TORCH HOLDING ASSEMBLY / PARTS LIST / EXPLODED VIEW

ITEM	QTY	PART NUMBER	DESCRIPTION
1	1	SLP-0246-05-01-00-1	Torch Holding Horizontal
2	1	C07182-460-50-20	Clamp Block
3	1	C07182-460-50-30	Rotate Block
4	1	C07182-331-20-31	Block Clamping I
5	1	C07182-331-20-40	Block Clamping II
6	1	C07182-460-50-40	Sleeve
7	1	C07182-460-50-50	Torch Washer 10, 1 x 15 x1
8	1	SRB-000187	Knurled Thumb Screw M6 x40
9	1	H00643-480-01-02	Handlever M6-16
10	2	N60091-305-10-00	Set Screw, M5 x 10
11	1	N18220-204-08-01	Screw, Cross Recessed M4 x 8
12	2	N18230-205-25-00	Screw, Soc Hd Cap M5 X 25
13	1	PRS-000002	External Retaining Ring 10Z

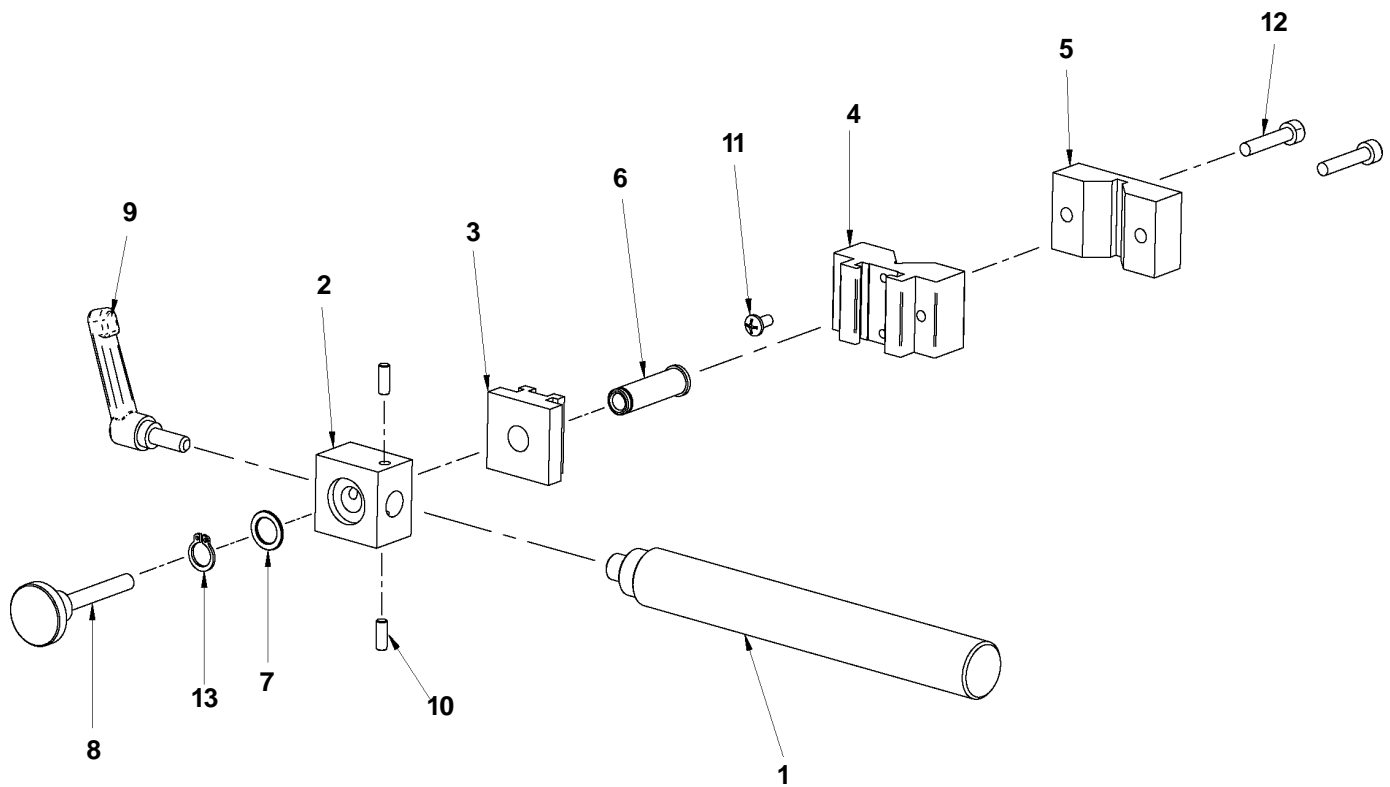

W07507-251-00-01 TILTED GUIDE RF-2 ASSY / PARTS LIST / EXPLODED VIEW

ITEM	QTY	PART NUMBER	DESCRIPTION
1	1	C07582-510-00-60	Angle Follower Arm-Wheels
2	1	C07582-510-00-20	Revolving Arm Bar
3	1	RLK-0251-00-04-00-0	Wheel
4	1	C07582-510-00-50	Axle-Wheel Sleeve
5	1	N18200-608-04-02	Round Washer 8.4
6	1	N18200-606-04-01	Round Washer 6.4
7	1	NKR-000078	Hex Cap Nut
8	1	H00643-480-01-00	Handlever M6-25

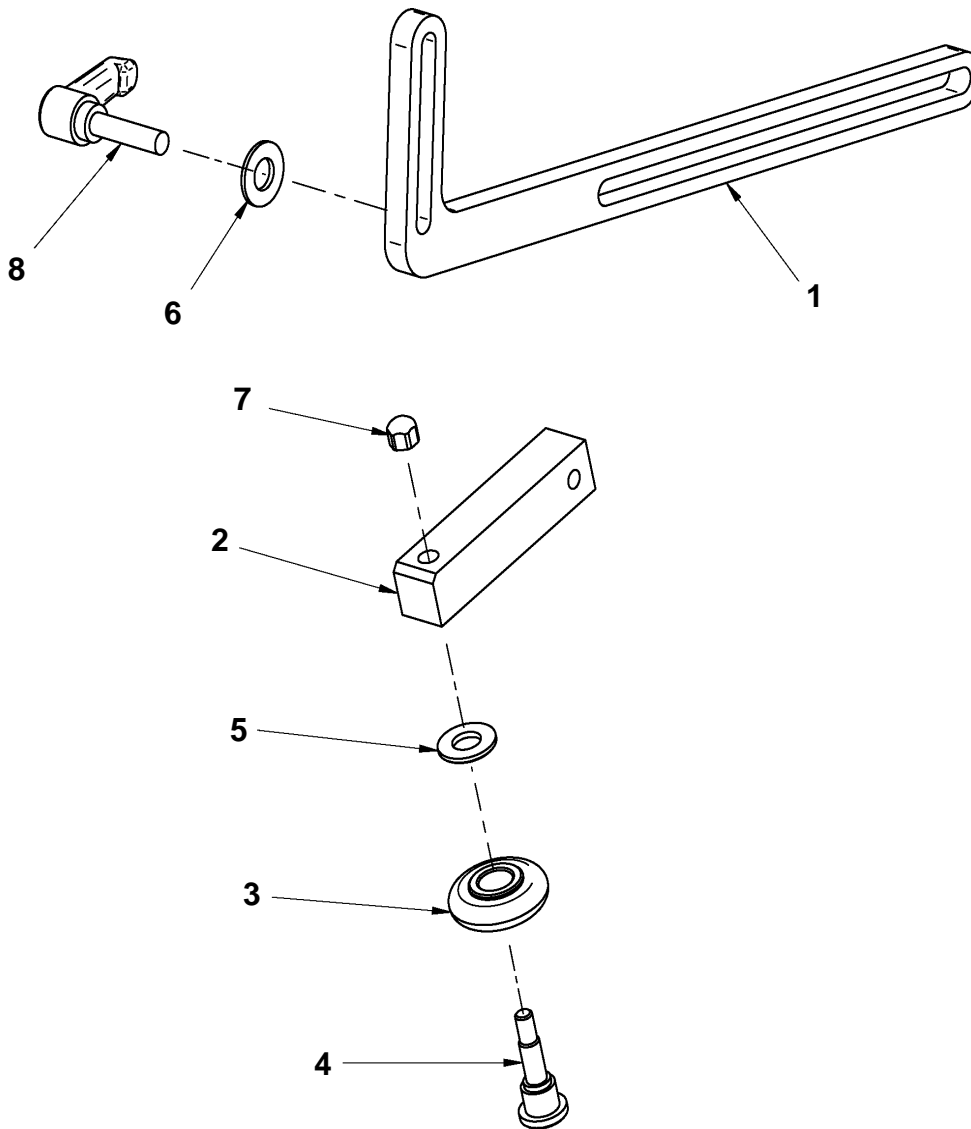

WARRANTY

LIMITED WARRANTY

MODEL _____
SERIAL NO. _____
DATE PURCHASED: _____

FOR A PERIOD OF TWELVE (12) MONTHS FROM DELIVERY, BUG-O SYSTEMS WARRANTS TO THE ORIGINAL PURCHASER (DOES NOT INCLUDE AUTHORIZED DISTRIBUTORS), THAT A NEW MACHINE IS FREE FROM DEFECTS IN MATERIAL AND WORKMANSHIP AND AGREES TO REPAIR OR REPLACE, AT ITS OPTION, ANY DEFECTIVE PARTS OR MACHINE. THIS WARRANTY DOES NOT APPLY TO MACHINES, WHICH AFTER OUR INSPECTION, ARE DETERMINED TO HAVE BEEN DAMAGED DUE TO NEGLIGENCE, ABUSE, OVERLOADING, ACCIDENT OR IMPROPER USAGE. ALL SHIPPING AND HANDLING CHARGES WILL BE PAID BY CUSTOMER.

BUG-O SYSTEMS MAKES NO WARRANTY OF MERCHANTABILITY AND MAKES NO OTHER WARRANTY, EXPRESSED OR IMPLIED, BEYOND THE WARRANTY EXPRESSLY SET FORTH ABOVE. BUYER'S REMEDY FOR BREACH OF WARRANTY, HEREUNDER, SHALL BE LIMITED TO REPAIR OR REPLACEMENT OF NON-CONFORMING PARTS AND MACHINES. UNDER NO CIRCUMSTANCES SHALL CONSEQUENTIAL DAMAGES BE RECOVERABLE.

HOW TO OBTAIN SERVICE:

IF YOU THINK THIS MACHINE IS NOT OPERATING PROPERLY, RE-READ THE INSTRUCTION MANUAL CAREFULLY, THEN CALL YOUR AUTHORIZED BUG-O DEALER/DISTRIBUTOR. IF HE CANNOT GIVE YOU THE NECESSARY SERVICE, WRITE OR PHONE US TO TELL US EXACTLY WHAT DIFFICULTY YOU HAVE EXPERIENCED. BE SURE TO MENTION THE MODEL AND SERIAL NUMBERS.