

INSTRUCTIONS and PARTS MANUAL

STAND ALONE PENDULUM WEAVER

Please record your equipment identification information below for future reference. This information can be found on your machine nameplate.

Model Number _____

Serial Number _____

Date of Purchase _____

Whenever you request replacement parts or information on this equipment, always supply the information you have recorded above.

LIT-SAPW-IPM-0610



BUG-O SYSTEMS
A DIVISION OF WELD TOOLING CORPORATION



161 HILLPOINTE DRIVE CANONSBURG, PENNSYLVANIA, 15317-9564 USA
PHONE: 1-412-331-1776 <http://www.bugo.com> FAX: 1-412-331-0383

SAFETY

PROTECT YOURSELF AND OTHERS FROM SERIOUS INJURY OR DEATH. KEEP CHILDREN AWAY. BE SURE THAT ALL INSTALLATION, OPERATION, MAINTENANCE AND REPAIR PROCEDURES ARE PERFORMED ONLY BY QUALIFIED INDIVIDUALS.



ELECTRIC SHOCK can kill.

1. The equipment is not waterproof. Using the unit in a wet environment may result in serious injury. Do not touch equipment when wet or standing in a wet location.
2. The unused connectors have power on them. Always keep the unused connectors covered with the supplied protective panels. Operation of the machine without the protective panels may result in injury.
3. Never open the equipment without first unplugging the power cord or serious injury may result.
4. Verify the customer-supplied power connections are made in accordance with all applicable local and national electrical safety codes. If none exist, use International Electric Code (IEC) 950.
5. Never remove or bypass the equipment power cord ground. Verify the equipment is grounded in accordance with all applicable local and national electrical safety codes. In none exist, use International Electric Code (IEC) 950.

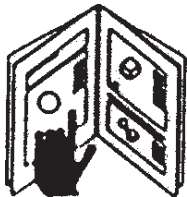

READ INSTRUCTIONS.

Read the instruction manual before installing and using the equipment.



EQUIPMENT DAMAGE POSSIBLE.

1. Do not plug in the power cord without first verifying the equipment is OFF and the cord input voltage is the same as required by the machine or serious damage may result.
2. Always verify both the pinion and wheels are fully engaged before applying power or equipment damage may occur.
3. Do not leave the equipment unattended.
4. Remove from the worksite and store in a safe location when not in use.



FALLING EQUIPMENT can cause serious personal injury and equipment damage.

Faulty or careless user installation is possible. As a result, never stand or walk underneath equipment.



MOVING PARTS can cause serious injury.

1. Never try to stop the pinion from moving except by removing power or by using the STOP control.
2. Do not remove any protective panels, covers or guards and operate equipment.

HIGH FREQUENCY WARNINGS

SPECIAL PRECAUTIONS ARE REQUIRED WHEN USING PLASMA, TIG OR ANY WELDING PROCESS THAT USES HIGH FREQUENCY TO STRIKE AN ARC.



WARNING: HIGH FREQUENCY CAN EFFECT MACHINE OPERATION AND THEREFORE, WELD QUALITY

Read the precautions below before installing and using the equipment.

PRECAUTIONS:

- 1) Some plasma or welding cables are strong sources of high frequency interference. NEVER lay a plasma or welding cable across the controls of the machine.
- 2) Always physically separate the plasma or welding cable leads from the machine cables. For example, the plasma or welding cable leads should NEVER be bundled with a pendant cable or the machine power cord. Maximize the separation between any machine cables and the plasma or welding cables.
- 3) Strictly follow the grounding procedures specified for the plasma or welding unit. NOTE: Some plasma and welding units produce exceptionally large amounts of high frequency noise. They may require a grounding rod be driven into the earth within six feet (2 meters) of the plasma or welding unit to become compatible with an automatic cutting or welding process.
- 4) If the high frequency is produced using a spark gap, adjust the points so the gap is as small as possible. The larger the gap, the higher the voltage and the higher the interference.
- 5) Some plasma or welding units will inject high frequency interference into the AC power line. Use separate power line branches whenever possible to power the plasma or welding source and the machine. Do not plug them into the same outlet box.
- 6) High frequency noise may enter the machine through the plasma or welding supply remote contactor leads. Some plasma and welding sources can produce noise spikes of up to several thousand volts. These sources are not compatible with automated cutting and welding equipment. It is recommended that the remote contactor leads on these plasma or welding sources not be connected to the machine. An alternate solution is to purchase a separate remote contactor isolation box.

STAND ALONE PENDULUM WEAVER INSTRUCTIONS AND PARTS MANUAL

TABLE OF CONTENTS

PAGE

5	Introduction / Features
6	Major Components / Pictorial
7	Set Up and Alignment
8	Technical Data
9	Gear Box and Mounting Box, Exploded View
10	BUG-6330, Control Box / Functions
11	BUG-6330, Control Box / Exploded View
12	BUG-6330, Control Box / Parts List
13	BUG-6330, Control Box / Wiring Diagram
14	BUG-6336, Connector Wiring Harness
15	BUG-6337, 6318, Timer, Weave Wiring Harnesses
16	BUG-5570 Power Circuit Box / Exploded View / Parts List
17	Power Circuit Box / Wiring Diagram
18	Warranty

**THIS PRODUCT IS COVERED BY ONE OR
MORE PATENTS WORLD WIDE.**

BUG-6350 STAND ALONE PENDULUM WEAVER

INTRODUCTION

The **Stand Alone Pendulum Weaver** is meant to be a self contained machine used for weave welding. It can be installed as part of a welding fixture, or mounted on a drive carriage running on a track. It can also be mounted directly on a BUG-O DC- I drive unit, and has provision to supply power to the DC-I. (shown below)

The Pendulum Weaver is particularly useful for weaving fillet welds in a corner joint. The Weaver box is attached on the end of an adjustable rack, held by a rackholder that can be mounted on the front of the drive carriage, or directly on the welding fixture.

FEATURES

- High torque, low inertia motor for precise starts and stops.
- Heavy duty planetary gear box with powerful output shaft for rotating welding gun and attachments for the gun.
- Uniform pendulum motion with independent control of right and left dwell times.
- High motor gearing ratio, that prevents the welding gun moving by backdriving the gear train when power is off.
- Closed loop speed control for adjustable and repeatable control of critical welding parameters.
- Closed loop position control to prevent drift from the center position.
- Gun mounting group with adjustable linkage for accurate positioning of the gun.
- Weld Contactor ON/OFF switch.

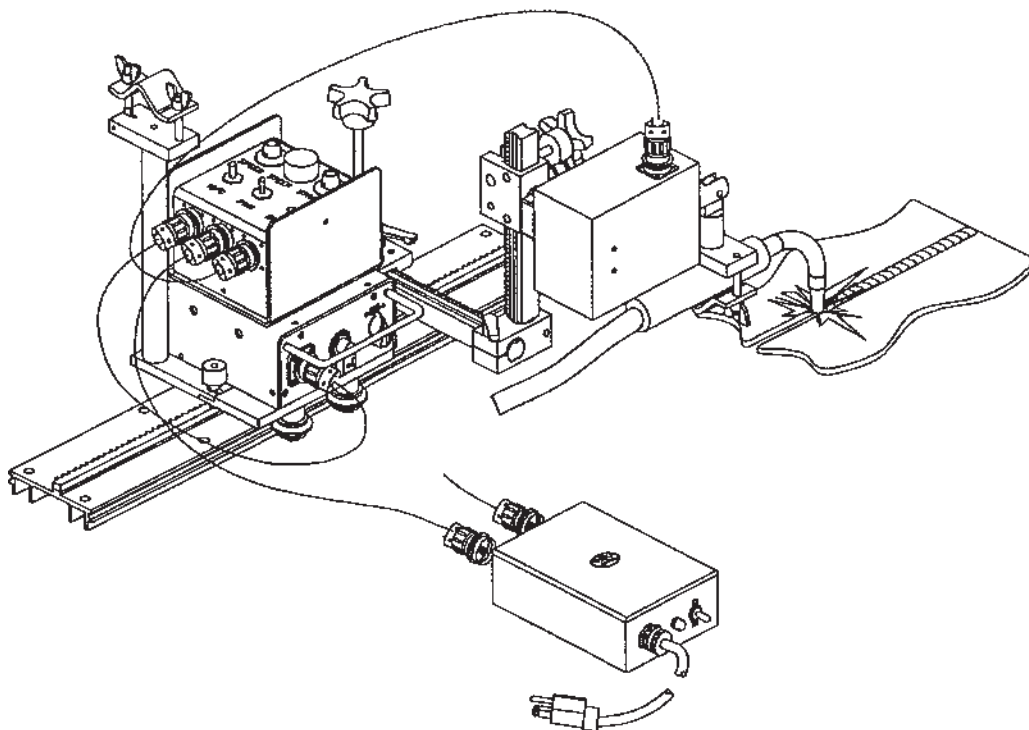

BUG-6350: STAND ALONE PENDULUM WEAVER

MAJOR COMPONENTS

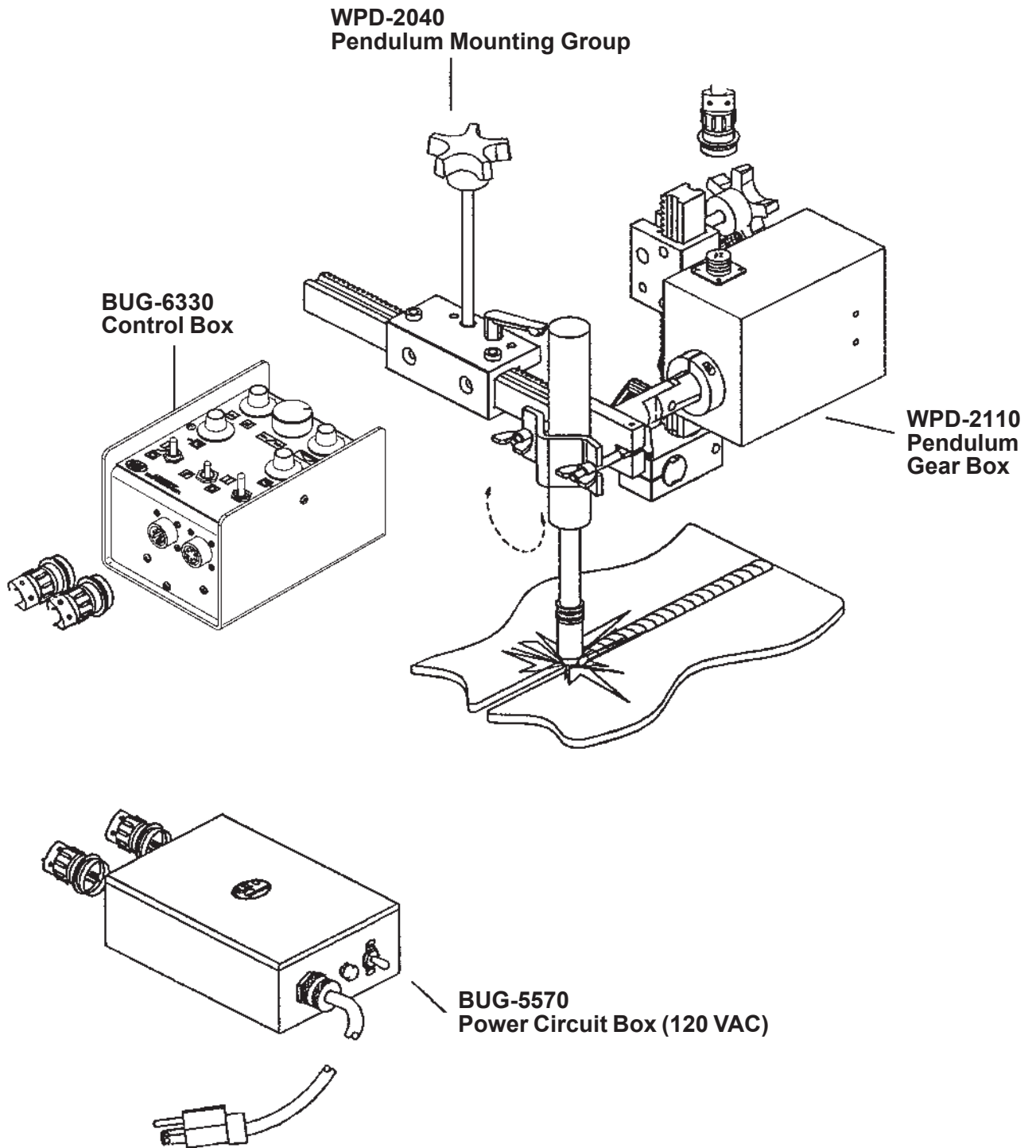

SET UP AND ALIGNMENT

If using a track drive, attach the rail parallel to the weld joint, with magnet bars or vacuum cups. Position the drive carriage on the rail, mount the Control Box on the drive, and attach the rack holder to the drive unit or carriage.

Position and clamp the pendulum gearbox on the rack.

Insert the welding gun into the fits-all clamp on the pendulum weaver. Adjust the racks and clamps to align the welding gun tip with the weld joint, and clamp firmly in place.

IMPORTANT!

When the welding gun is clamped in place with the nozzle pointing into the weld groove, the centerline of the wire must pass through the axis of the gearbox output shaft, as shown in Figure A, which is a view looking along the shaft. Figure B shows the side view of the same.

For a fillet weld, the nozzle will be at a 45° angle as shown in Figure C, and will swing equally in both directions.

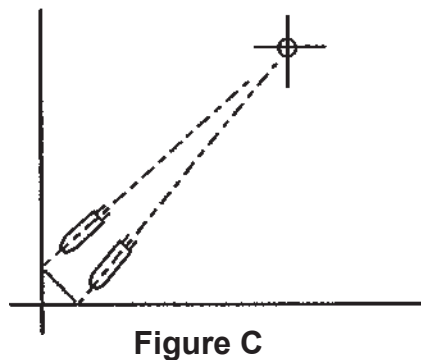
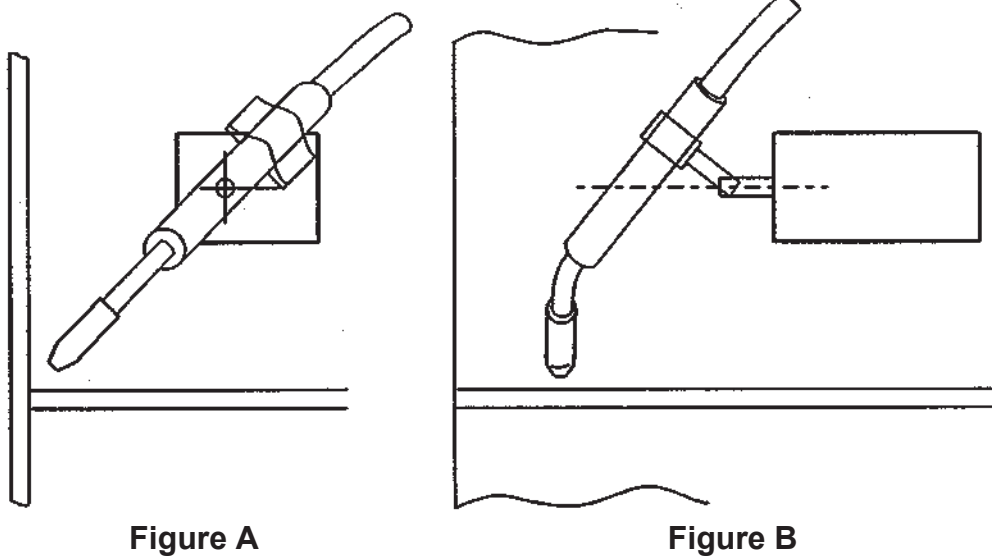

TECHNICAL DATA

BUG-6350 STAND ALONE PENDULUM WEAVER

Power Requirements:	Uses 40 watts	BUG-6350	120 VAC
		BUG-6352	240 VAC
		BUG-6354	42 VAC
Dimensions:	3.3"W x 4.1"H x 5.7"L (84 x 104 x 144 mm)		
Gearbox:	3.3"W x 4.1"H x 5.7"L (84 x 104 x 144 mm)		
Control Box:	5.13"L x 5.0"W x 4.13"H (130 mm x 127 mm x 105 mm)		
Net Weight:	18 lbs. (8.2 kg)		
Speed:*	0-200 ipm (0-5100 mm/m)		
Cycles:*	2 cps at 1/4" (6 mm) stroke 1 cps at 1" (25 mm) stroke (at maximum speed and 0 dwell)		
Stroke:*	2" (50 mm)		
Steering:*	4" (100 mm) - 2" (50 mm) each side of center.		
	* all measured at a 6" radius		
Dwell Time:	0-3 seconds, left or right.		
Load Capacity:	10 lbs (4.5 kg)		

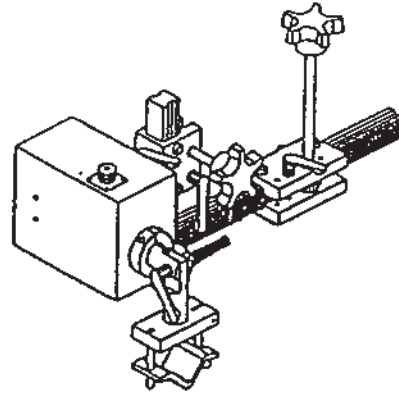

DIMENSIONS

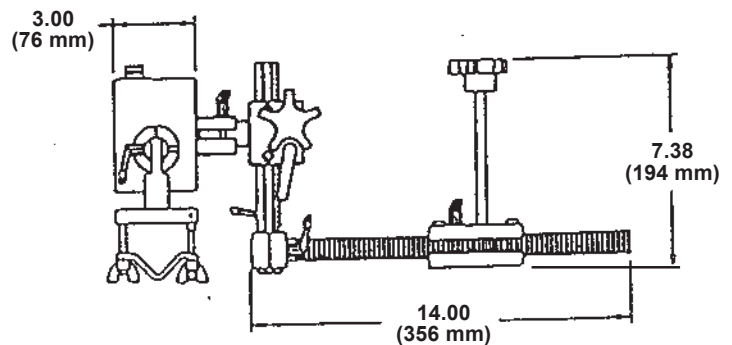
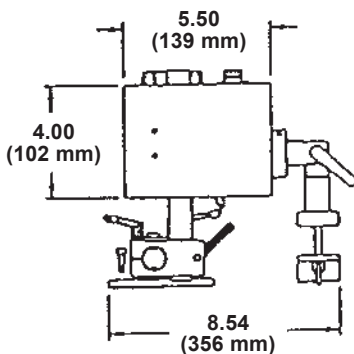
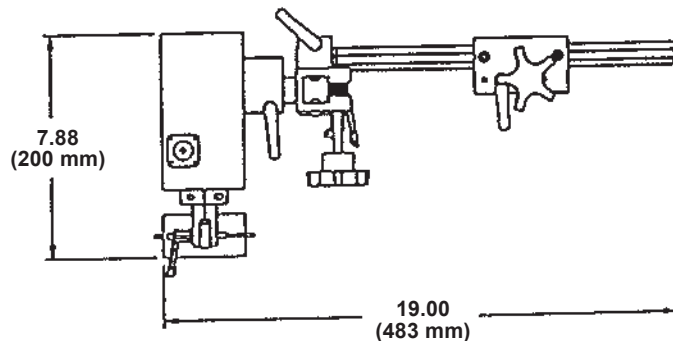

PENDULUM GEARBOX AND MOUNTING GROUP EXPLODED VIEW

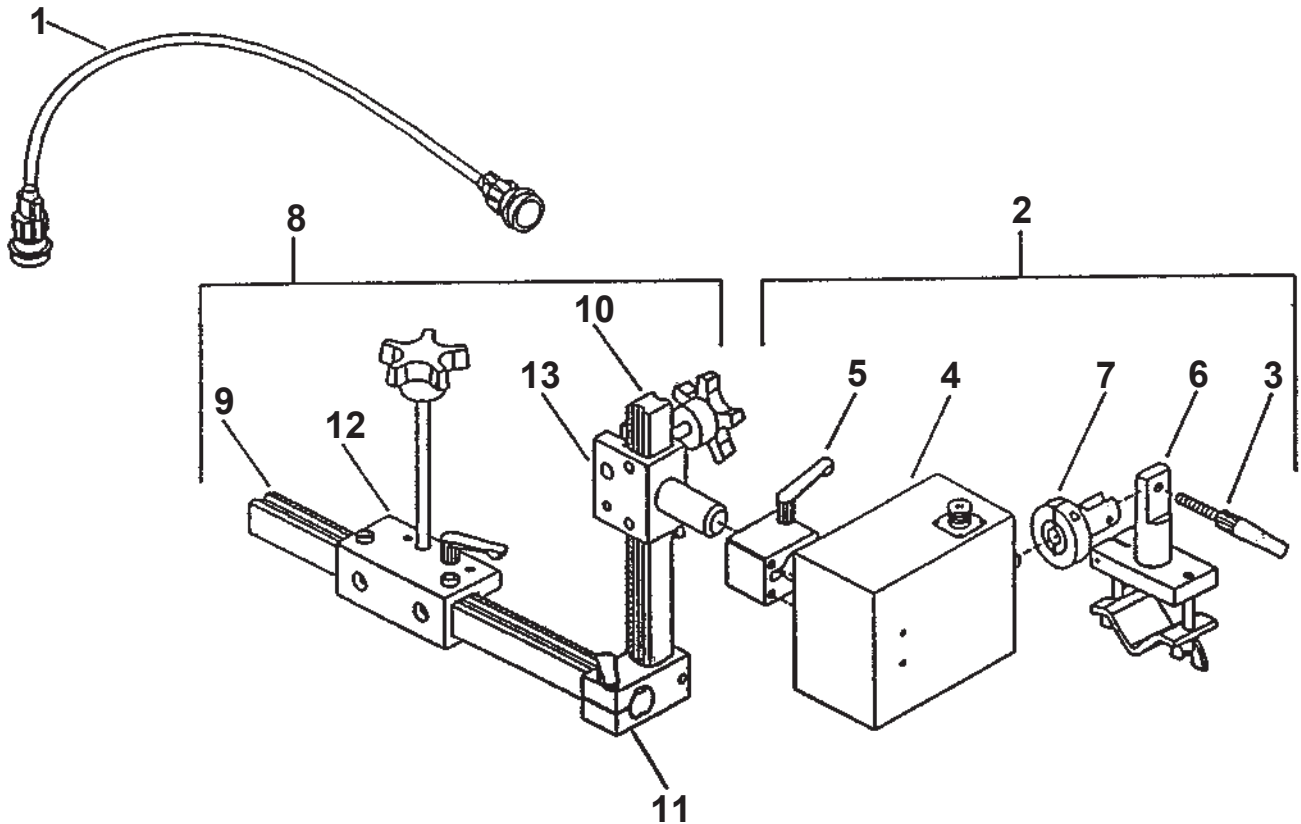

PARTS LIST

ITEM	QTY	PART NO.	DESCRIPTION
1	1	BUG-5571	Power Cable, 10'
2	1	WPD-2110	Pendulum Gear Box (includes items 3 through 7)
3	1	BUG-2234	Adjustable Clamping Lever
4	1	WPD-2110-P	Gear Box
5	1	WPD-2041	Clamp Block
6	1	WPD-2042	Gun Clamp
7	1	WPD-2044	Shaft Adaptor w/Collar
8	1	WPD-2040	Pendulum Mounting Group (includes items 9 through 13)
9	1	BUG-1796	Machined Rack 14"
10	1	BUG-1853	Machined Rack 7-1/2"
11	1	BUG-5462	Right Angle Clamp
12	1	MDS-1031	3.5" Rackholder w/Long Handle
13	1	UNI-1036	Rackrider w/Post

BUG-6330 / CONTROL BOX

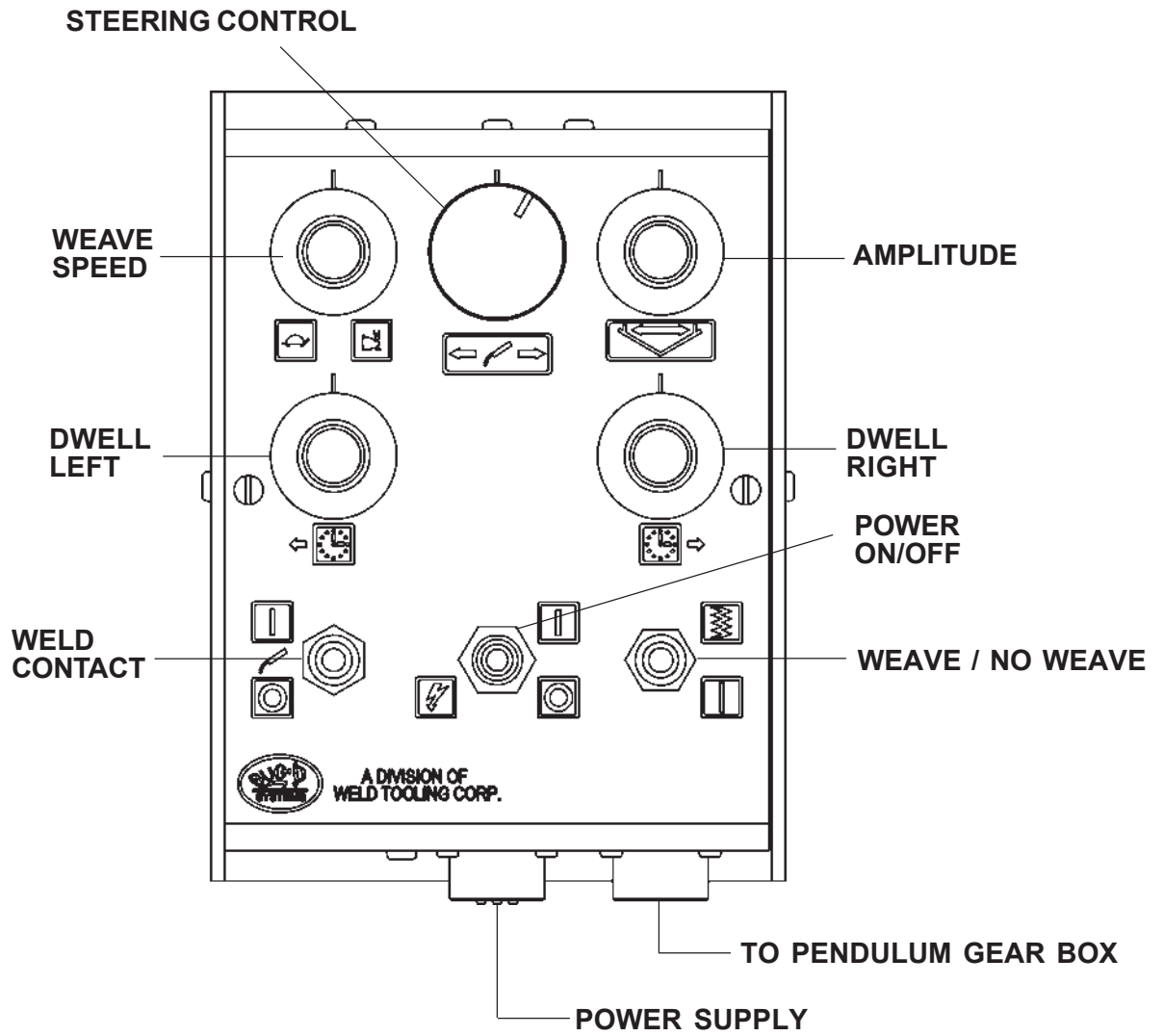

BUG-6330 / CONTROL BOX / EXPLODED VIEW

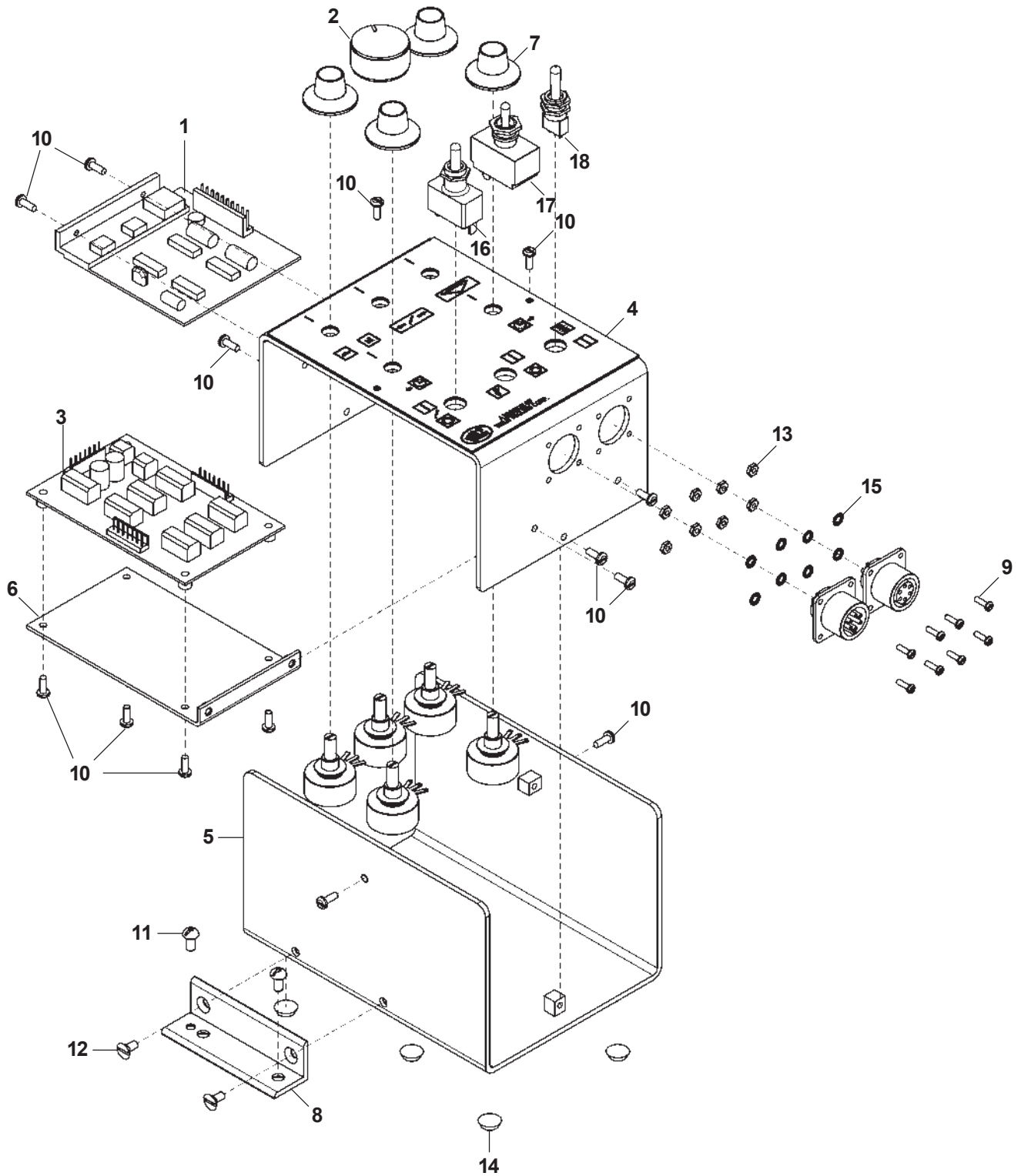

BUG-6330 CONTROL BOX / PARTS LIST

ITEM	PART NO.	QTY	DESCRIPTION
1	BUG-1770-PW	1	Motor Control Board
2	BUG-5757	1	Knob
3	BUG-5760	1	Control Board
4	BUG-6331	1	Front Panel
5	BUG-6332	1	Rear Panel
6	BUG-6333	1	Mounting Bracket
7	BUG-9621	4	Knob
8	CDS-1068	1	Mounting Bracket
9	FAS-0104	8	Pan Hd. Scr. 4-40 x 3/8 Lg.
10	FAS-0114	14	Pan Hd. Scr. 6-32 x 3/8 Lg.
11	FAS-0224	2	Pan Hd. Scr. 10-32 x 3/8 Lg.
12	FAS-0824	2	Flat Hd. Slit. Scr. 8-32 x 3/8 Lg.
13	FAS-1305	8	Hex Nut 4/40
14	SFX-1292	4	Bumper
15	WAS-0201-4	4	#4 Internal Star Lock Washer
16	BUG-1869	1	SW-3 Toggle Switch, SPDT
17	BUG-5761	1	SW-2 Toggle Switch, SPDT
18	ARM-2279	1	SW-1 Toggle Switch, DPST
*	BUG-6336	1	Connector Wiring Harness
*	BUG-6318	1	Weave Wiring Harness
*	BUG-6337	1	Timer Wiring Harness

* not shown

BUG-6330 CONTROL BOX / WIRING DIAGRAM

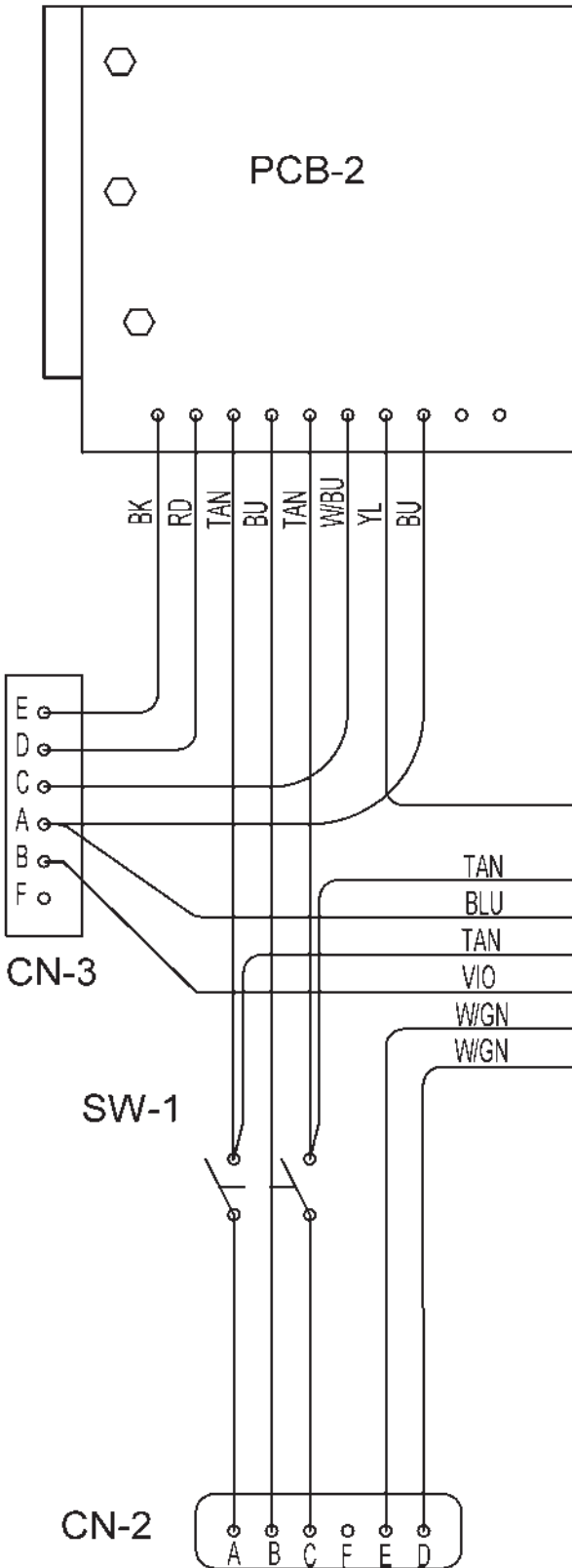

ELECTRICAL COMPONENTS

ITEM	PART NO.	DESCRIPTION
CN-2	BUG-9909	Panel Connector, 6-T, M
CN-3	BUG-9902	Panel Connector, 6-T, F
P-1,2,3	BUG-9677	Pot, 10 K
P-4,P-5	BUG-5054	Pot, 500 K
PCB-1	BUG-5760	Control Board
PCB-2	BUG-1770-PW	Motor Control Board
SW-1	ARM-2279	Toggle Switch, DPST
SW-2	BUG-5761	Toggle Switch, SPDT
SW-3	BUG-1869	Toggle Switch, SPDT

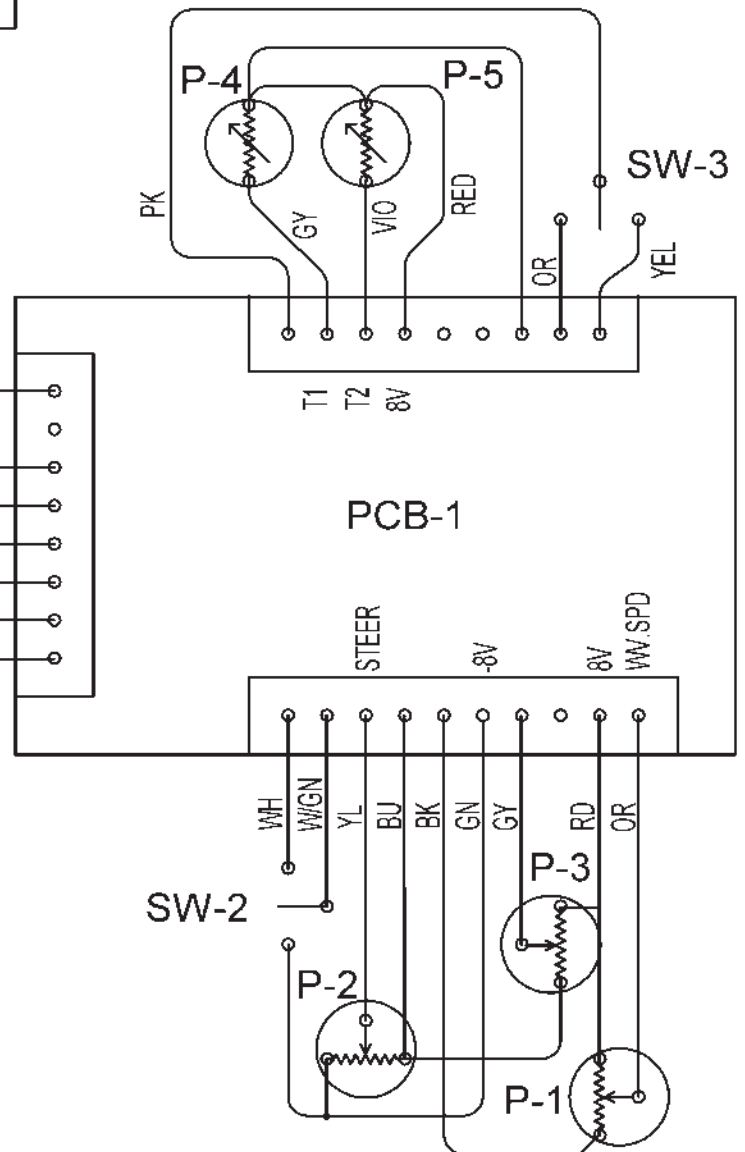

CONNECTOR WIRING HARNESS

BUG-6336

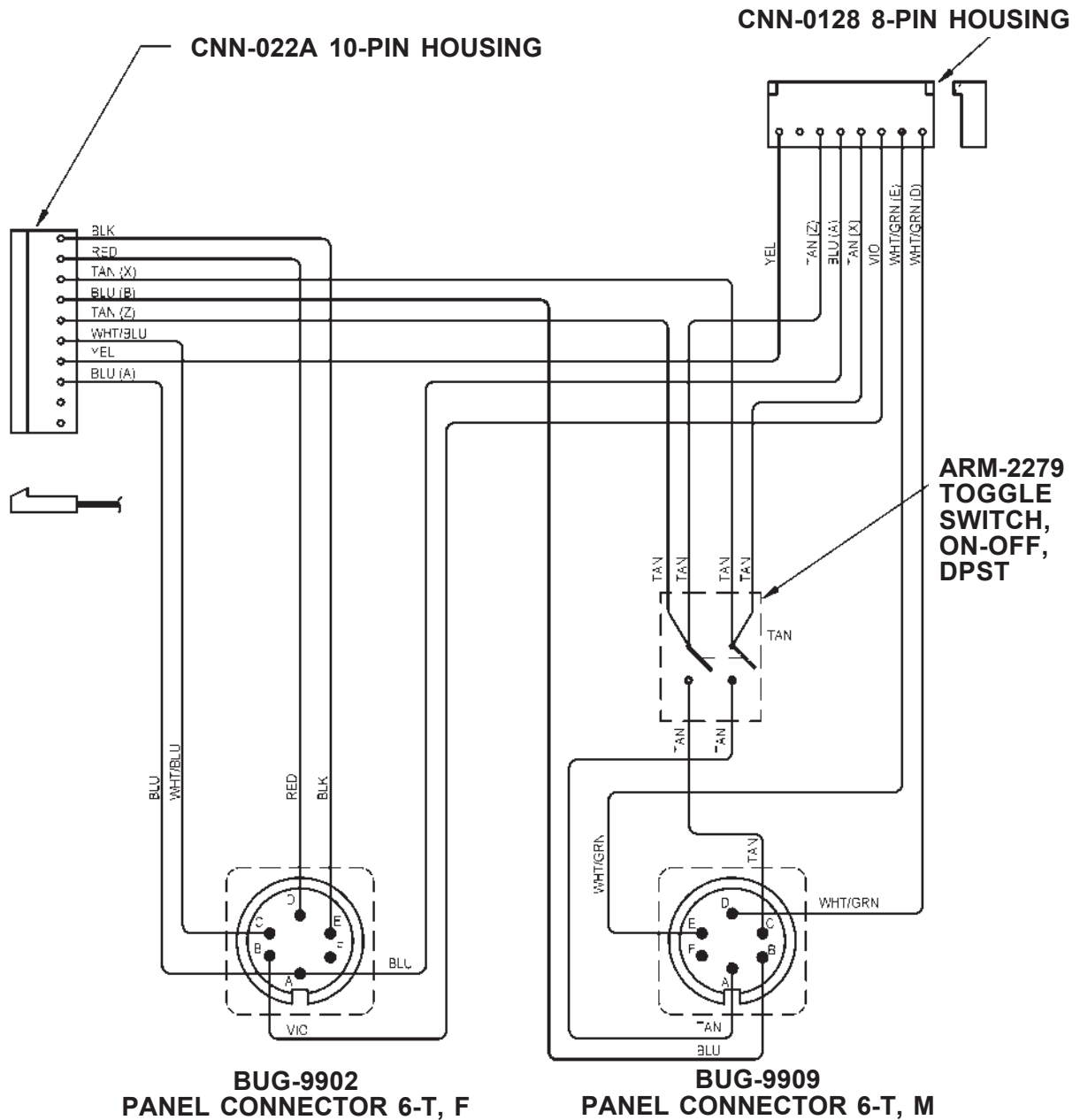

TIMER WIRING HARNESS

BUG-6337

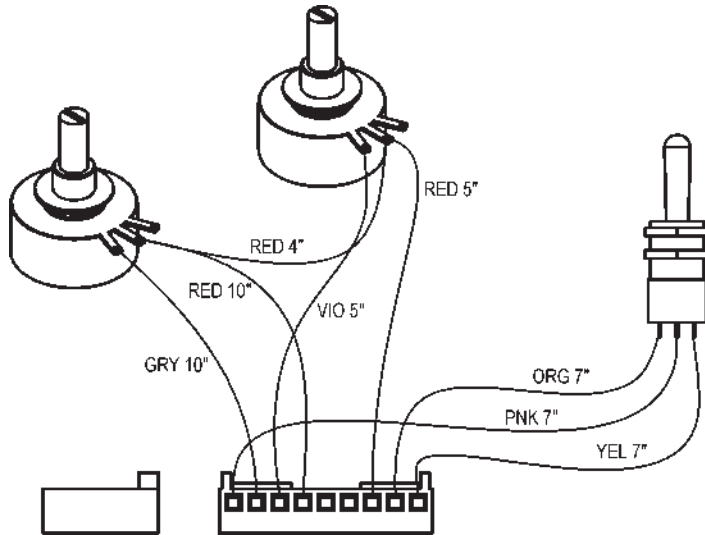

WEAVE WIRING HARNESS

BUG-6318

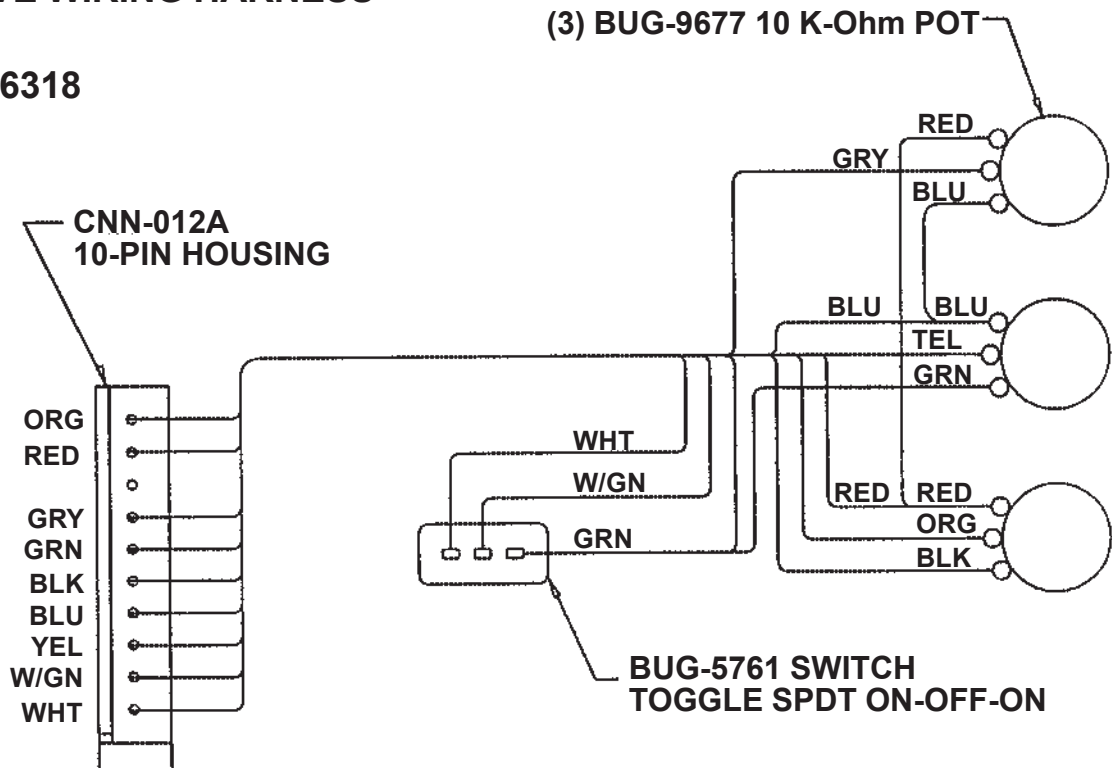

BUG-5570 POWER CIRCUIT BOX / EXPLODED VIEW

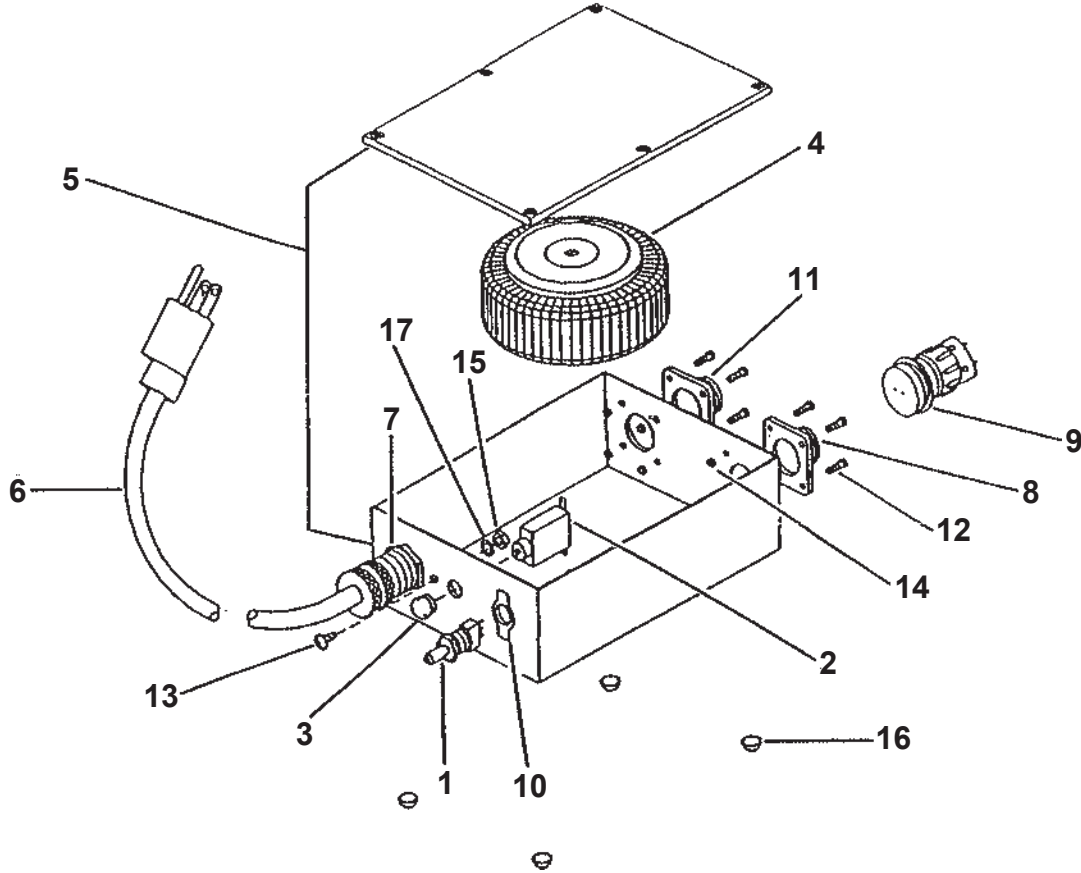

BUG-5570 POWER CIRCUIT BOX 120 V / PARTS LIST

ITEM	QTY	PART NUMBER	DESCRIPTION
1	1	ARM-2279	Toggle Switch
*2	1	BUG-2923	Circuit Breaker .7A
3	1	BUG-2924	Reset Button Seal
*4	1	BUG-5218	Transformer
5	1	BUG-5573	Enclosure
*6	1	BUG-9445	Power Cord
7	1	BUG-9446	Cord Grip
8	1	BUG-9486	Panel Connector, 2-T, M
9	1	BUG-9487	Cable Connector, 2-T, F
10	1	BUG-9884	On-Off Switch Plate
11	1	BUG-9902	Panel Connector, 6-T, F
12	8	FAS-0204	Rnd Hd Scr 4-40 x 3/8
13	1	FAS-1224	But Hd Soc Hd Scr 8-32 x 3/8
14	8	FAS-1305	Hex Nut 4-40
15	1	FAS-1320	Hex Nut 8-32
16	4	SFX-1292	Bumper
17	1	WAS-0221	#8 Star Lockwasher

* See Electrical Component Chart for 240 VAC and 42 VAC Part Numbers

POWER CIRCUIT BOX / WIRING DIAGRAM

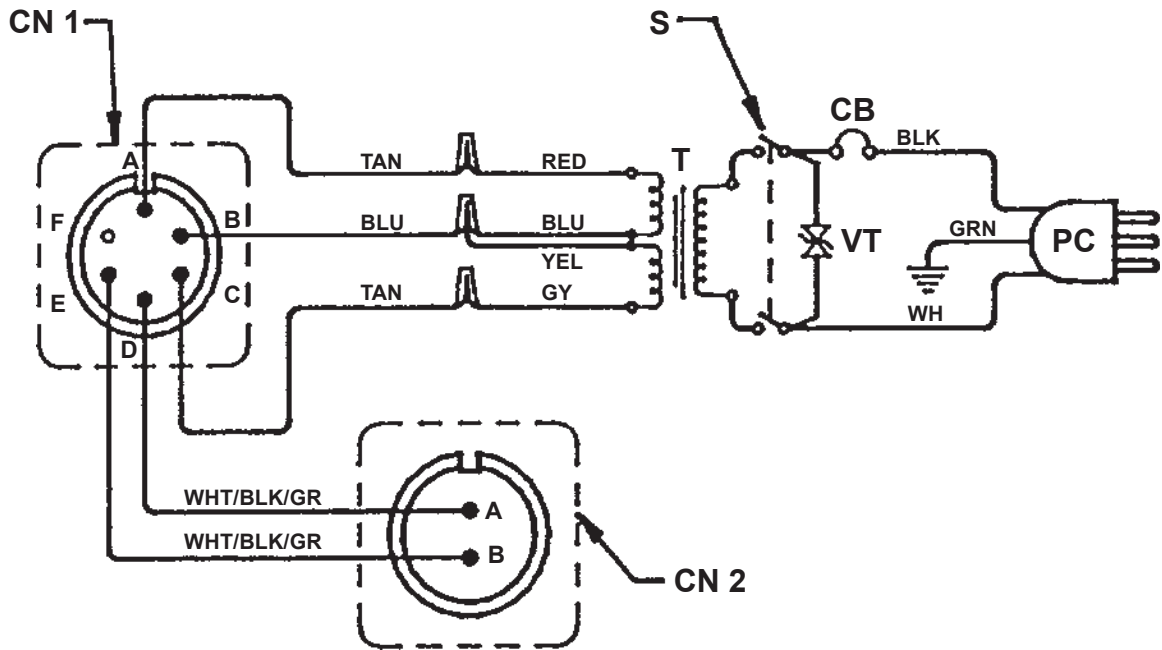

ELECTRICAL COMPONENT CHART

ITEM	DESCRIPTION	BUG-5570	BUG-5572	BUG-5574
		120 VAC PART NO.	240 VAC PART NO.	42 VAC PART NO.
CB	Circuit Breaker	BUG-2923	BUG-2952	BUG-2933
PC	Power Cord	BUG-9445	GOF-3115	BUG-9442
T	Transformer	BUG-5218	BUG-5231	BUG-5232
VT	Volt Trap	BUG-1393	BUG-1563	BUG-1393
CN-1	Panel Connector		BUG-9902	
CN-2	Panel Connector		BUG-9486	
S	Toggle Switch		ARM-2279	

WARRANTY

Limited Warranty

Model _____
Serial No. _____
Date Purchased: _____

For a period of twelve (12) months from delivery, BUG-O Systems warrants to the original purchaser (does not include authorized distributors), that a new machine is free from defects in material and workmanship and agrees to repair or replace, at its option, any defective parts or machine. This warranty does not apply to machines, which after our inspection, are determined to have been damaged due to neglect, abuse, overloading, accident or improper usage. All shipping and handling charges will be paid by customer.

BUG-O Systems makes no warranty of merchantability and makes no other warranty, expressed or implied, beyond the warranty expressly set forth above. Buyer's remedy for breach of warranty, hereunder, shall be limited to repair or replacement of non-conforming parts and machines. Under no circumstances shall consequential damages be recoverable.

HOW TO OBTAIN SERVICE:

If you think this machine is not operating properly, re-read the instruction manual carefully, then call your Authorized BUG-O dealer/distributor. If he cannot give you the necessary service, write or phone us to tell us exactly what difficulty you have experienced. BE SURE to mention the MODEL and SERIAL numbers.