

INSTRUCTIONS AND PARTS MANUAL

FTS w/ AUTOMATIC HEIGHT CONTROL

FTS-1025

Please record your equipment identification information below for future reference. This information can be found on your machine nameplate.

Model Number _____

Serial Number _____

Date of Purchase _____

Whenever you request replacement parts or information on this equipment, always supply the information you have recorded above.

LIT-FTS-AHC-IPM-0309



BUG-O SYSTEMS
A DIVISION OF WELD TOOLING CORPORATION



280 TECHNOLOGY DRIVE CANONSBURG, PENNSYLVANIA 15317-9564 USA
PHONE: 1-412-331-1776 <http://www.bugo.com> FAX: 1-412-331-0383

SAFETY

PROTECT YOURSELF AND OTHERS FROM SERIOUS INJURY OR DEATH. KEEP CHILDREN AWAY. BE SURE THAT ALL INSTALLATION, OPERATION, MAINTENANCE AND REPAIR PROCEDURES ARE PERFORMED ONLY BY QUALIFIED INDIVIDUALS.



ELECTRIC SHOCK can kill.

- 1) The equipment is not waterproof. Using the unit in a wet environment may result in serious injury. Do not touch equipment when wet or standing in a wet location.
- 2) The unused connectors have power on them. Always keep the unused connectors covered with the supplied protective panels. Operation of the machine without the protective panels may result in injury.
- 3) Never open the equipment without first unplugging the power cord or serious injury may result.
- 4) Verify the customer-supplied power connections are made in accordance with all applicable local and national electrical safety codes. If none exist, use International Electric Code (IEC) 950.
- 5) Never remove or bypass the equipment power cord ground. Verify the equipment is grounded in accordance with all applicable local and national electrical safety codes. If none exist, use International Electric Code (IEC) 950.



READ INSTRUCTIONS.

Read the instruction manual before installing and using the equipment.



EQUIPMENT DAMAGE POSSIBLE.

- 1) Do not plug in the power cord without first verifying the equipment is OFF and the cord input voltage is the same as required by the machine or serious damage may result.
- 2) Always verify both the pinion and wheels are fully engaged before applying power or equipment damage may occur.
- 3) Do not leave the equipment unattended.
- 4) Remove from the worksite and store in a safe location when not in use.



FALLING EQUIPMENT can cause serious personal injury and equipment damage.

Faulty or careless user installation is possible. As a result, never stand or walk underneath equipment.



MOVING PARTS can cause serious injury.

- 1) Never try to stop the pinion from moving except by removing power or by using the STOP control.
- 2) Do not remove any protective panels, covers or guards and operate equipment.

HIGH FREQUENCY WARNINGS

SPECIAL PRECAUTIONS ARE REQUIRED WHEN USING PLASMA, TIG OR ANY WELDING PROCESS THAT USES HIGH FREQUENCY TO STRIKE AN ARC.



WARNING: HIGH FREQUENCY CAN EFFECT MACHINE OPERATION AND THEREFORE, WELD QUALITY.

Read the precautions below before installing and using the equipment.

PRECAUTIONS:

- 1) Some plasma or welding cables are strong sources of high frequency interference. NEVER lay a plasma or welding cable across the controls of the machine.
- 2) Always physically separate the plasma or welding cable leads from the machine cables. For example, the plasma or welding cable leads should NEVER be bundled with a pendant cable or the machine power cord. Maximize the separation between any machine cables and the plasma or welding cables.
- 3) Strictly follow the grounding procedures specified for the plasma or welding unit. NOTE: Some plasma and welding units produce exceptionally large amounts of high frequency noise. They may require a grounding rod be driven into the earth within six feet (2 meters) of the plasma or welding unit to become compatible with an automatic cutting or welding process.
- 4) If the high frequency is produced using a spark gap, adjust the points so the gap is as small as possible. The larger the gap, the higher the voltage and the higher the interference.
- 5) Some plasma or welding units will inject high frequency interference into the AC power line. Use separate power line branches whenever possible to power the plasma or welding source and the machine. Do not plug them into the same outlet box.
- 6) High frequency noise may enter the machine through the plasma or welding supply remote contactor leads. Some plasma and welding sources can produce noise spikes of up to several thousand volts. These sources are not compatible with automated cutting and welding equipment. It is recommended that the remote contactor leads on these plasma or welding sources not be connected to the machine. An alternate solution is to purchase a separate remote contactor isolation box.

FTS w/ AUTOMATIC HEIGHT CONTROL

FTS-1025

INSTRUCTIONS AND PARTS MANUAL

TABLE OF CONTENTS

SAFETY	2
INTRODUCTION	5
FEATURES	5
TECHNICAL DATA	5
CONNECTING THE SHUNT	6
AUTOMATED HEIGHT CONTROL	6
WHEEL ADJUSTMENT	6
RACKER MAINTENANCE	6
AHC CONTROL UNIT	7
FTS-1025 FTS with AUTOMATED HEIGHT CONTROL / PARTS LIST / EXPLODED VIEW	8
FTS-1030-NC F/S TORCH SUPPORT w/ MOTOR. HEIGHT / PARTS LIST / EXPLODED VIEW	9
FTS-1015 DUAL RACKER WITH VERTICAL MOTOR / PARTS LIST / EXPLODED VIEW	10
CAS-1210-FTS AMP SENSING CONTROL UNIT / PARTS LIST / EXPLODED VIEW	11
CAS-1210-FTS AMP SENSING CONTROL UNIT / WIRING DIAGRAM	12
AMP SENSING CONTROL UNIT / ELECTRICAL COMPONENT CHART	12
CAS-1025 SHUNT & FILTER ASS'Y / PARTS LIST / EXPLODED VIEW	13
CAS-1025 SHUNT & FILTER ASS'Y / WIRING DIAGRAM	13
CWO-1697 MOTOR ASS'Y / PARTS LIST / EXPLODED VIEW	14
ACCESSORIES	15
WARRANTY	17
HOW TO OBTAIN SERVICE:	17

INTRODUCTION

The FTS-1025 Freestanding Torch Support with Automated Height Control (AHC) is a compact easy to use system designed to maintain a constant torch-to-work distance automatically. A shunt continuously monitors the welding current, and the controller adjusts the torch height to maintain constant torch-to-work distance. Rack and pinion movement on hardened V-ways provides smooth and effortless positioning of the welding gun or cutting torch. Can be used with Sub-Arc, Innershield and MIG welding.

FEATURES

Multi-turn potentiometer with dial display for current set-point.

Automatic AHC shutoff for low current.

Built-in time delay after arc is struck, before AHC begins current sensing.

Manual jog to override AHC while welding.

Speed control potentiometer sets speed during manual operation, limits top speed for AHC.

Four quadrant motor for smooth vertical travel.

TECHNICAL DATA

Total Vertical Adjustment:	25" (635 mm)
Total Horizontal Adjustment:	25" (635 mm)
Net Weight:	49 lb (22 kg)
Power Supply:	120 VAC / 50-60 Hz / 1 Phase 240 VAC / 50-60 Hz / 1 Phase
Capacity:	20 lb (9 kg)

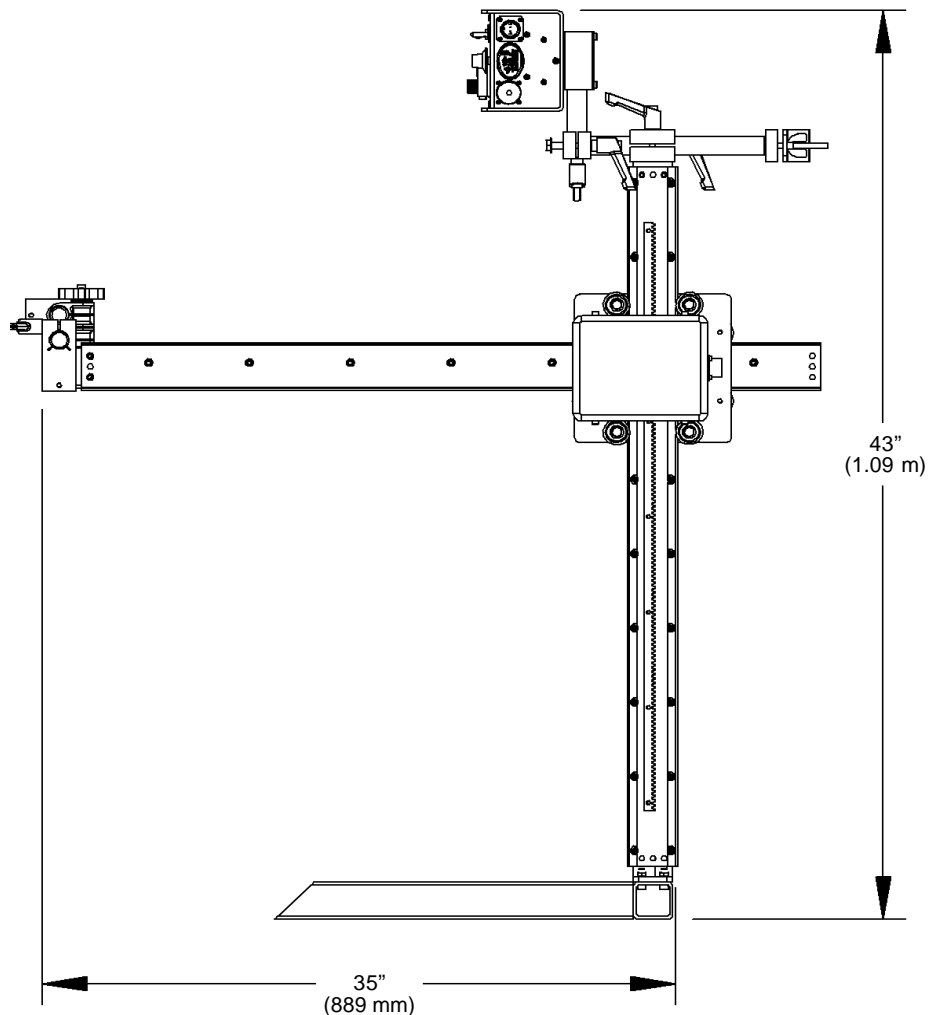

POWER SOURCE

Use only constant voltage type power sources with this welding device. If using a multiple process power source, be sure that it is set for constant voltage output as per the instructions in the power source manual. Set the power source polarity switch properly or connect the electrodes and work leads for the correct electrode polarity.

CONNECTING THE SHUNT

Connect the shunt “in-line” on the welding power source ground cable. The shunt’s positive lead and the signal output cable are located on the same side of the enclosure. For a positive electrode, this lead should be connected to the work piece.

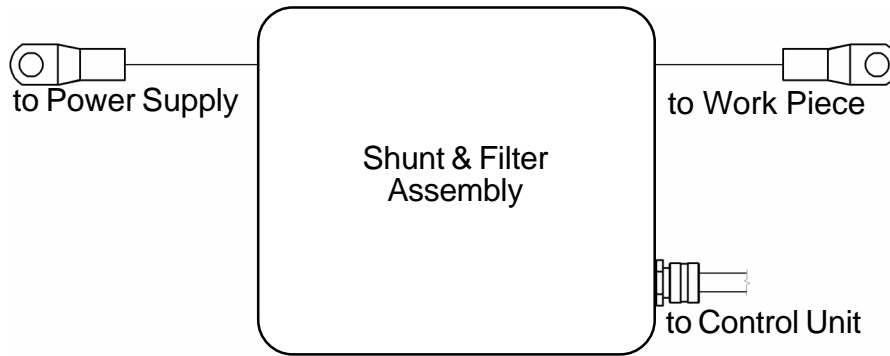

AUTOMATED HEIGHT CONTROL

The FTS-1025 features automated height control (AHC), which controls the welding tip to work distance and maintains a constant weld current that results in more uniform weld penetration. AHC continually senses and filters the actual weld current, then compares this value to the setpoint, and raises or lowers the welding gun accordingly. AHC features a built-in time delay after the arc is struck, and automatically shuts off when current drops too low (below 55 amp). The operator can temporarily override AHC using the manual jog switch while welding. AHC resumes as soon as the jog switch is released.

NOTE: AHC is designed to work with the welding gun *above* the work piece. Contact BUG-O Systems for other configurations.

WHEEL ADJUSTMENT

The ABR Dual Racker (FTS-1015) is equipped with wheels that ride along the V-ways. For each racker direction, one set of wheels is fixed and one set is adjustable. Check the racker unit for proper wheel adjustment before use. The wheels need adjustment if you can cock or wiggle components out of alignment. The wheels should be snug, but not prohibit movement along the path of travel.

The wheels with the hex stand off are adjustable (Pg 10, Item 13). To adjust the wheels, loosen the hex bolt (A) until the adjustable bushing (B) can be rotated. Correct the wheel alignment by rotating adjustable bushing (B). Once adjusted, hold the adjustable bushing (B) while tightening the hex bolt (A). Recheck alignment.

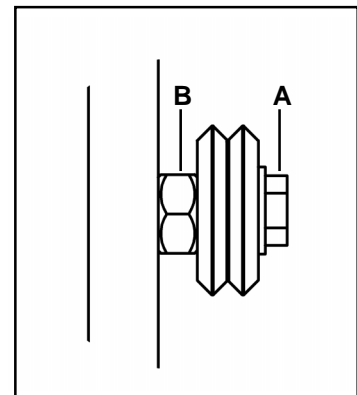

Adjustable Wheel

RACKER MAINTENANCE

BUG-O Systems recommends inspecting the racker system daily. Inspect the gear rack, V-ways and wheels. Remove all dirt, grease and rust. Inspect V-ways for nicks and replace as needed. Check wheel alignment and adjust as needed to maintain snug fit and smooth operation. Lubricate V-ways with dry spray lubricant. Lubricate pinion with dry Teflon or graphite spray.

AHC CONTROL UNIT

All vertical racking for the FTS-1025 is motorized and controlled with the AHC Control Unit (shown below).

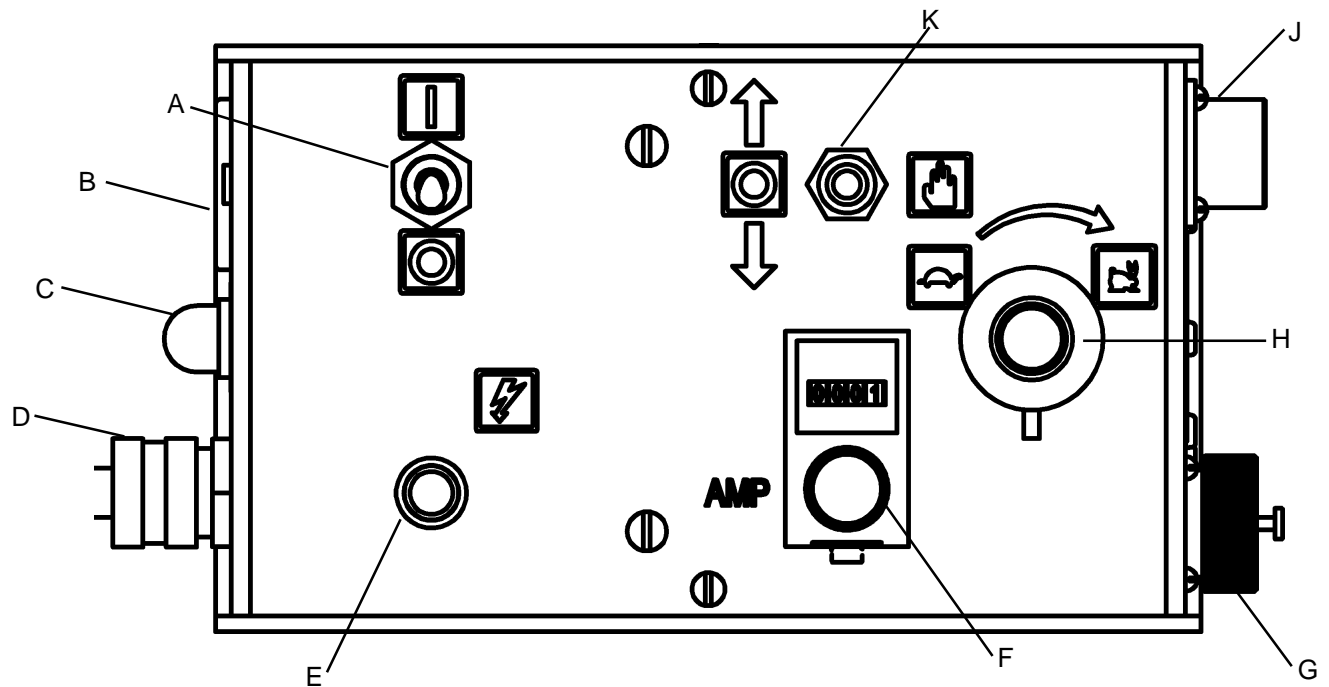

Features and Functions of the AHC Control Unit:

- A. Main Power Switch - Turn control power on or off.
- B. Auxiliary Power Receptacle
- C. Circuit Breaker Reset - Resets control circuit after overload.
- D. Power Cord - Input power to the Control Unit
- E. Pilot Light - Lit when Control Unit is plugged in and turned on.
- F. Current Set Point Control and Display - Displays AHC current setpoint (in amps); range 0 - 500 amps. Turn knob clockwise to increase set point, counterclockwise to decrease.
- G. Motor Connection (Cap & Chain) - Plug cable from motorized racker here.
- H. Speed Control - Regulates the speed of vertical travel. Turn knob clockwise to increase speed, counterclockwise to decrease.
- J. Shunt & Filter Receptacle - Connect cable from Shunt and Filter Assembly here.
- K. Manual Jog Switch - Used to raise and lower vertical racker when not welding. Overrides AHC when welding.

FTS-1025 FREESTANDING TORCH SUPPORT with AUTOMATED HEIGHT CONTROL / PARTS LIST / EXPLODED VIEW

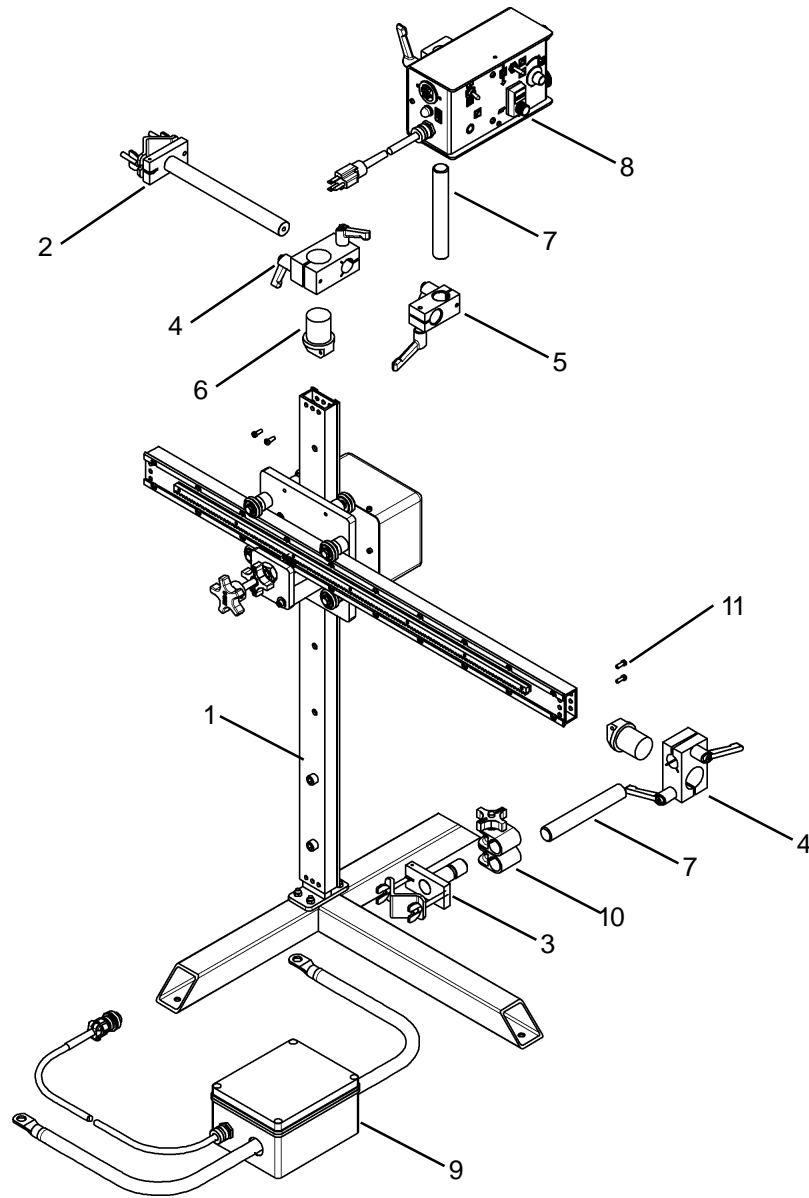

ITEM	QTY	PART No.	DESCRIPTION
1	1	FTS-1030-NC	F/S Torch Support with Motor. Height Ass'y
2	1	BUG-2668	Cable Anchor Bracket
3	1	BUG-2708	Clamp
4	2	BUG-5182	Right Angle Clamp
5	1	BUG-5462	Right Angle Clamp
6	2	BUG-5548	Swivel Rod Adaptor
7	1	BUG-9180-6	Rod, 6"
8	1	CAS-1210-FTS	Control Unit, Amp Sensing, 120V
	1	CAS-1212-FTS	Control Unit, Amp Sensing, 240V
9	1	CAS-1025	Filter & Shunt Ass'y
10	1	CON-1020	Swivel Clamp Ass'y
11	4	FAS-0555	Screw, Soc Hd Cap 1/4-20 x 1/2
12	1	FTS-1026	Cable Ass'y, 36" 2-T (Not Shown)

FTS-1030-NC F/S TORCH SUPPORT w/ MOTOR. HEIGHT / PARTS LIST / EXPLODED VIEW

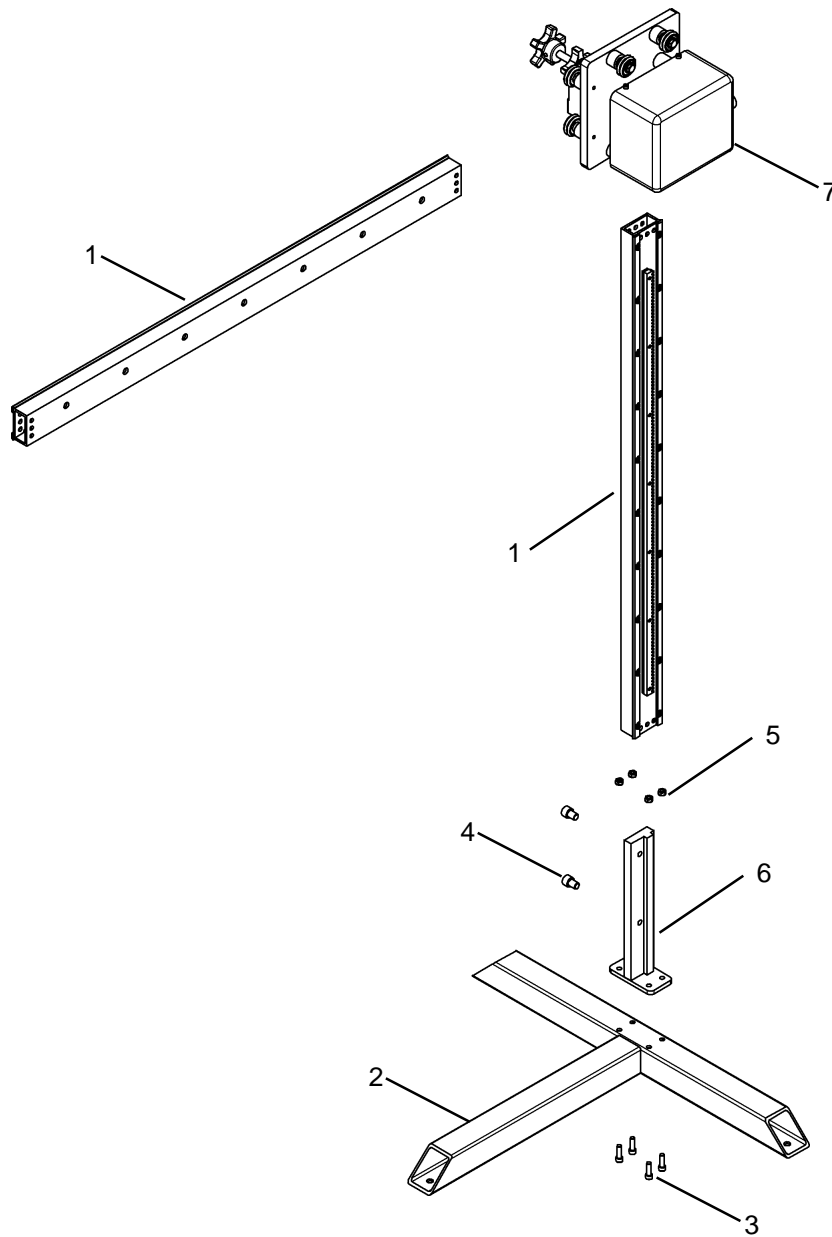

ITEM	QTY	PART No.	DESCRIPTION
1	2	ABR-1060	V-Guide Ways 33"
2	1	BUG-3605	Torch Support Base
3	4	FAS-0557	Screw, Soc Hd Cap 1/4-20 x 3/4
4	2	FAS-0595	Screw, Soc Hd Cap 3/8-16 x 1/2
5	4	FAS-1351	Hex Nut 1/4-20
6	1	FTS-1005	ABR Support Post
7	1	FTS-1015	Dual Racker w/ Motorized

FTS-1015 DUAL RACKER WITH VERTICAL MOTOR / PARTS LIST / EXPLODED VIEW

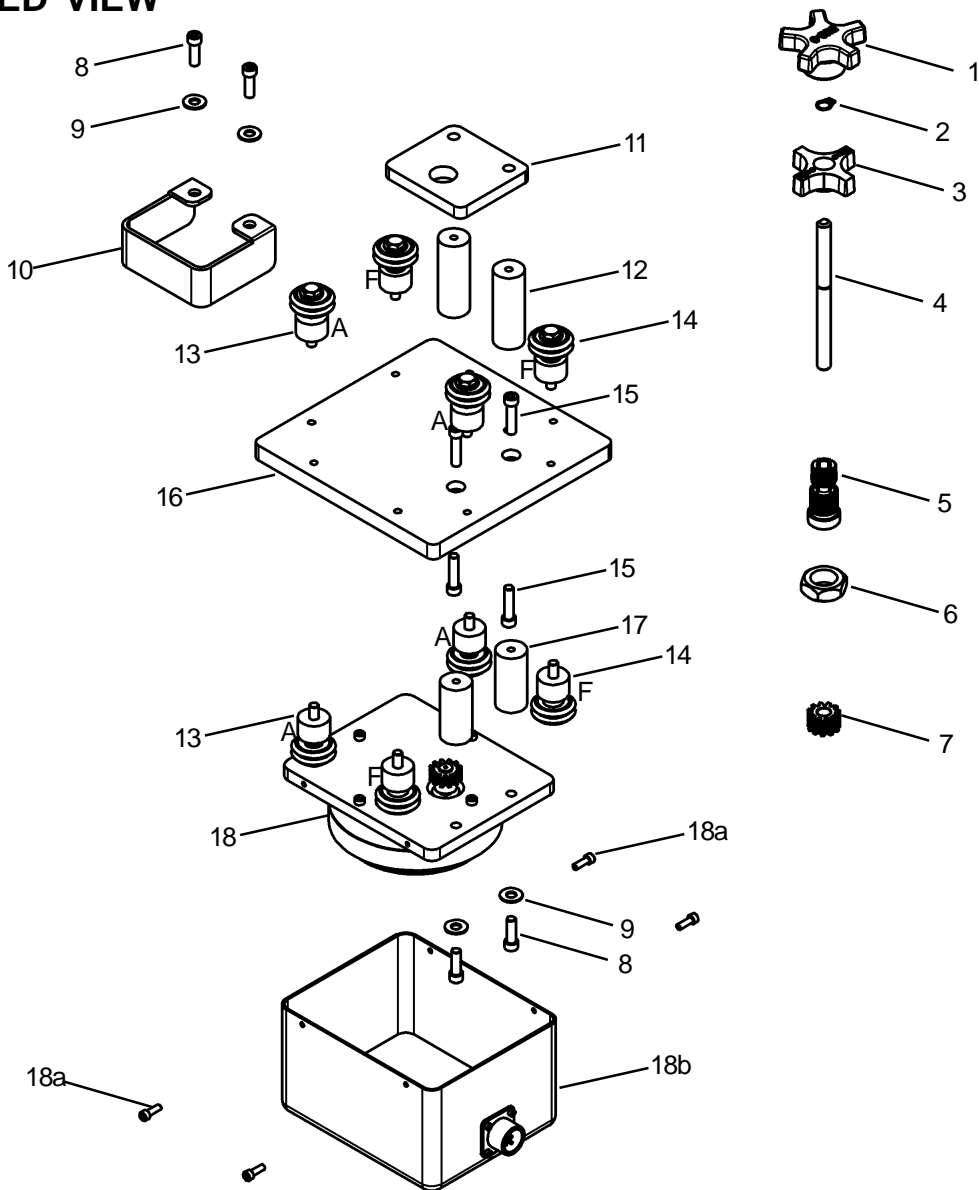

ITEM	QTY	PART No.	DESCRIPTION
1	1	BUG-2032	Knob, Black
2	1	MUG-1579	Retaining Ring, 3/8"
3	1	MUG-1142	Knob, Locking
4	1	MUG-1144	Shaft
5	1	MUG-1141	Bearing, Collet
6	1	FAS-1307	Hex Jam Nut, 3/4-16
7	1	CWO-1679	Pinion Gear
8	4	FAS-0557	Screw, Soc Hd Cap 1/4-20 x 3/4
9	4	WAS-0240	Washer, SAE Flat 1/4"
10	1	CWO-1671	Racker Shield
11	1	CWO-1678	Racker Plate
12	2	MUG-1453	Stand-Off, Manual Side
13	4	CWO-1681	W2 Adj. Leg & Wheel
14	4	CWO-1680	W2 Fixed Leg & Wheel
15	4	FAS-0559	Screw, Soc Hd Cap 1/4-20 x 1"
16	1	FTS-1011	Dual Racker Plate
17	2	CWO-1694	Stand-Off, Motor Side
18	1	CWO-1697	150:1 Motor Assembly (Includes 18a & 18b)
18a	4	FAS-0525	Screw, Soc Hd Cap 8-32 x 1/2
18b	1	CWO-1696	Motor Enclosure

CAS-1210-FTS AMP SENSING CONTROL UNIT / PARTS LIST / EXPLODED VIEW

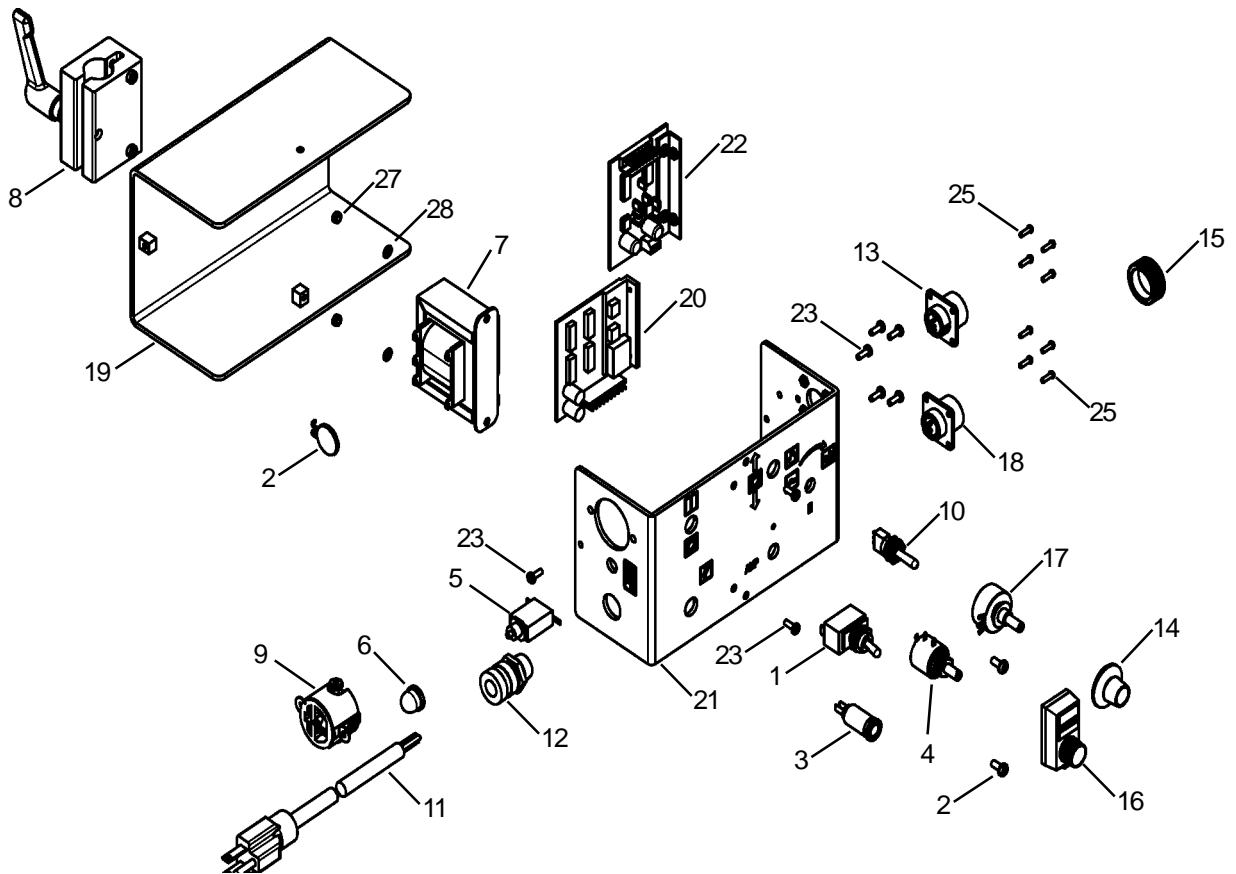

ITEM	QTY	PART No.	DESCRIPTION
1	1	ABP-1069	Toggle Switch
2	1	BUG-1393	Volt Trap 120 VAC
3	1	BUG-1415	Pilot Light
4	1	BUG-1572	Potentiometer, 10k
5	1	BUG-2923	0.7 Amp Circuit Breaker
6	1	BUG-2942	Reset Seal, Transparent
7	1	BUG-5001	Transformer 120 VAC
8	1	BUG-5295	Rod Mount Ass'y
9	1	BUG-5321	Single Power Receptacle
10	1	BUG-5323	Toggle Switch, On-Off-On
11	1	BUG-9445	Power Cord
12	1	BUG-9446	Cord Grip
13	1	BUG-9486	Panel Connector, 2T, Male
14	1	BUG-9621	Knob
15	1	BUG-9628	Cap & Chain Ass'y
16	1	BUG-9676	Dial Counter
17	1	POT WTE 2001	Potentiometer, 5k ohm
18	1	BUG-9856	Panel Connector, 2T, Female
19	1	CAS-1019	Rear Cover
20	1	CAS-1050	Arc Sensing Control
21	1	CAS-1218	Front Cover
22	1	CAS-1770	Speed Control (Iron Rotor)
23	8	FAS-0114	Screw, Pan Hd 6-32 x 3/8
24	2	FAS-0124	Screw, Pan Hd 8-32 x 3/8
25	8	FAS-0204	Screw, Rnd Hd Slit 4-40 x 3/8
26	8	FAS-1305	Hex Nut 4-40
27	2	FAS-1320	Hex Nut 8-32
28	2	WAS-0221	#8 Internal Star Lockwasher

CAS-1210-FTS AMP SENSING CONTROL UNIT / WIRING DIAGRAM

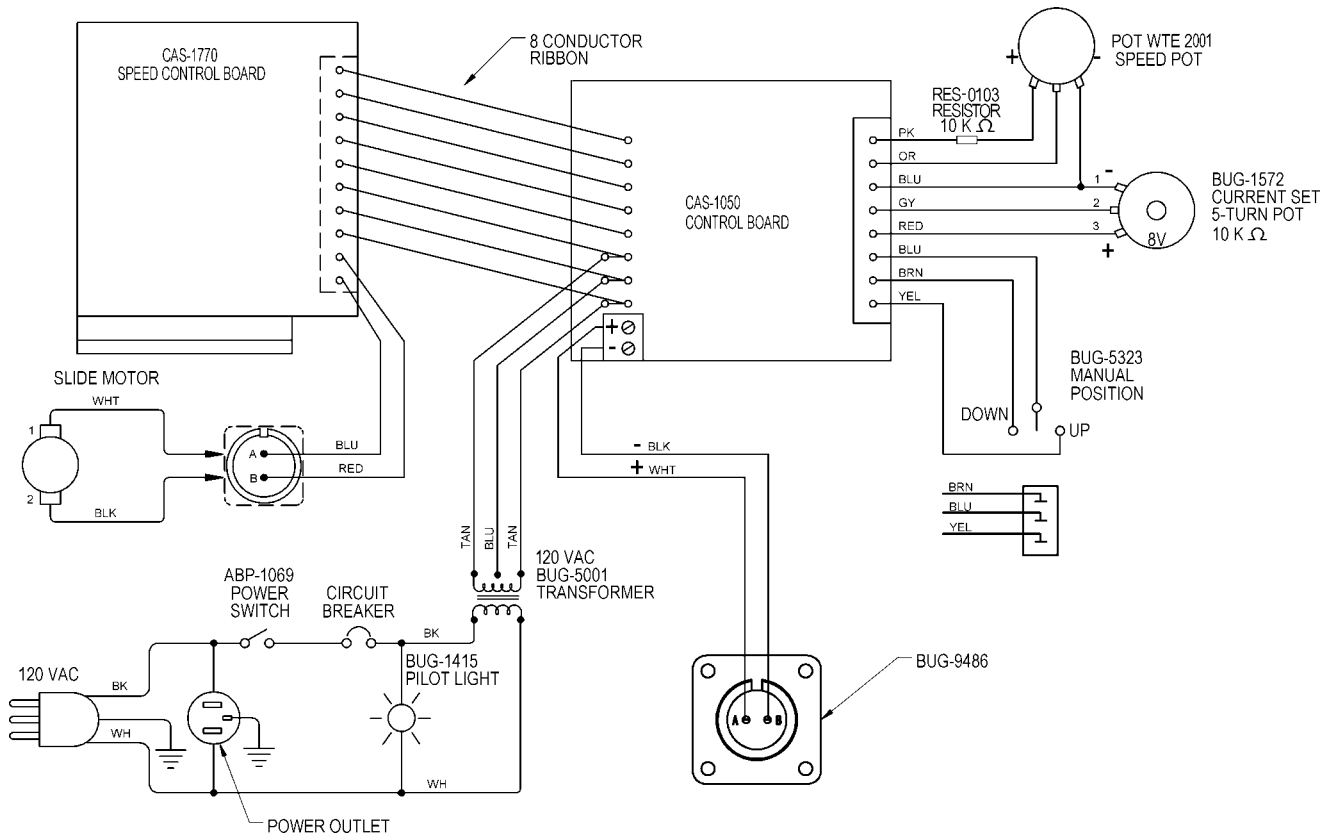

AMP SENSING CONTROL UNIT / ELECTRICAL COMPONENT CHART

DESCRIPTION	PART NO.	
	FTS-1025 (120 VAC)	FTS-1025-240 (240 VAC)
Control Unit	CAS-1210-FTS	CAS-1212-FTS
Power Cord	BUG-9445	GOF-3115
Auxiliary Power Receptacle	BUG-5321	BUG-9595
Transformer	BUG-5001	BUG-5002
Circuit Breaker	BUG-2923 (0.7 AMP)	BUG-2925 (0.5 AMP)
Volt Trap	BUG-1393	BUG-1563
Pilot Light	BUG-1415	BUG-1428

CAS-1025 SHUNT & FILTER ASS'Y / PARTS LIST / EXPLODED VIEW

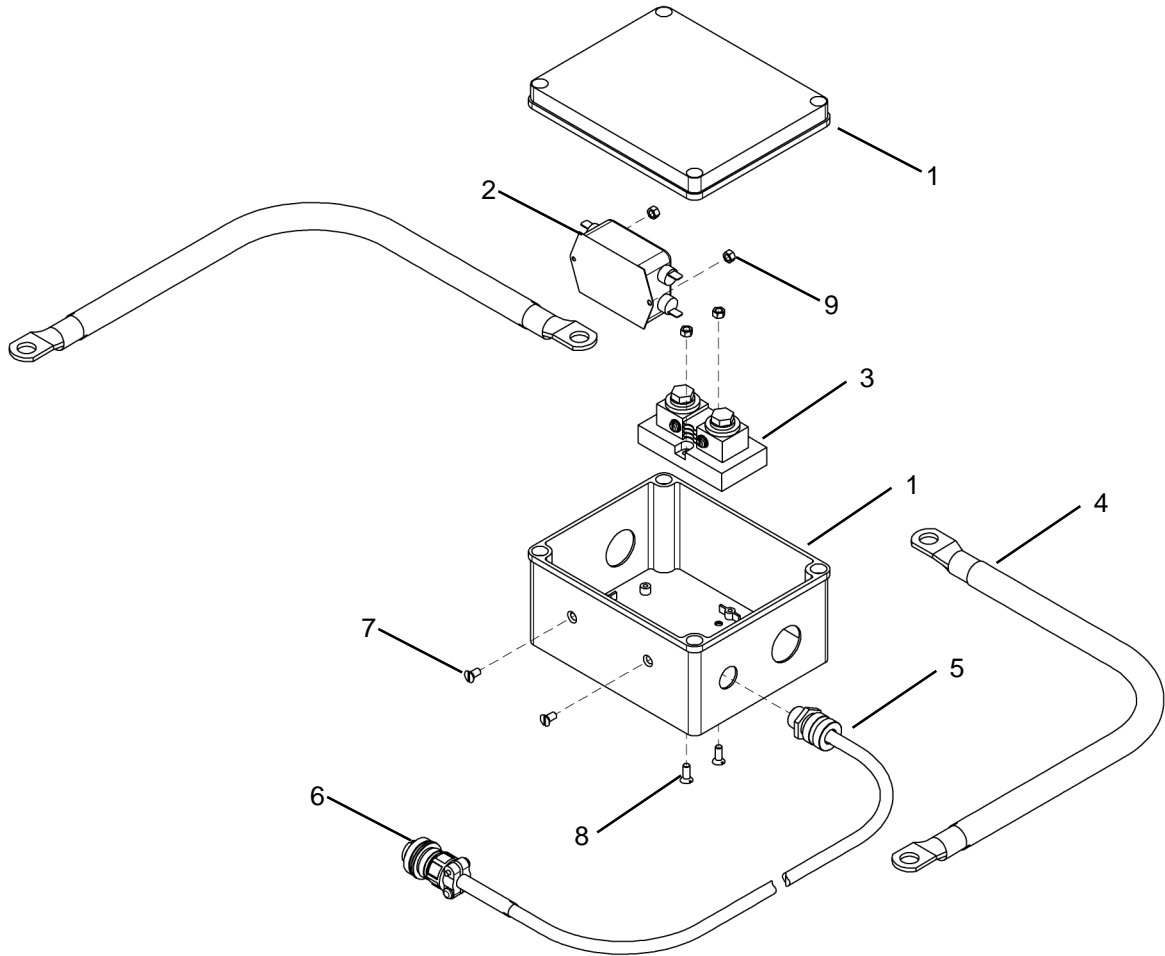

ITEM	QTY	PART No.	DESCRIPTION
1	1	CAS-1026	Enclosure
2	1	BUG-6069	Filter
3	1	BUG-6071	Shunt, 500 Amp, 50 mV
4	4	CWO-8061	Welding Lug, 1/0 - 2/0
5	1	BUG-9216	Cord Grip
6	1	BUG-9487	Cable Connector, 2-T
7	2	FAS-0834	Screw, Flat Hd 10-24 x 3/8
8	2	FAS-0835	Screw, Flat Hd 10-24 x 1/2
9	4	FAS-1330	Hex Nut 10-24

CAS-1025 SHUNT & FILTER ASS'Y / WIRING DIAGRAM

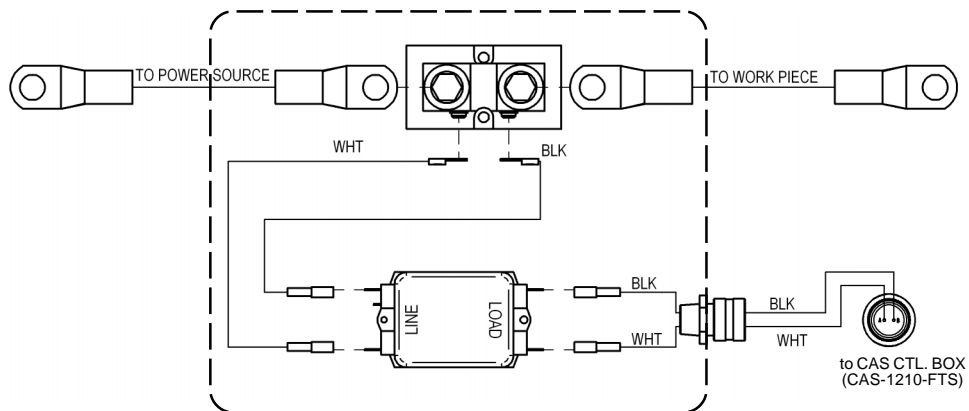

CWO-1697 MOTOR ASS'Y / PARTS LIST / EXPLODED VIEW

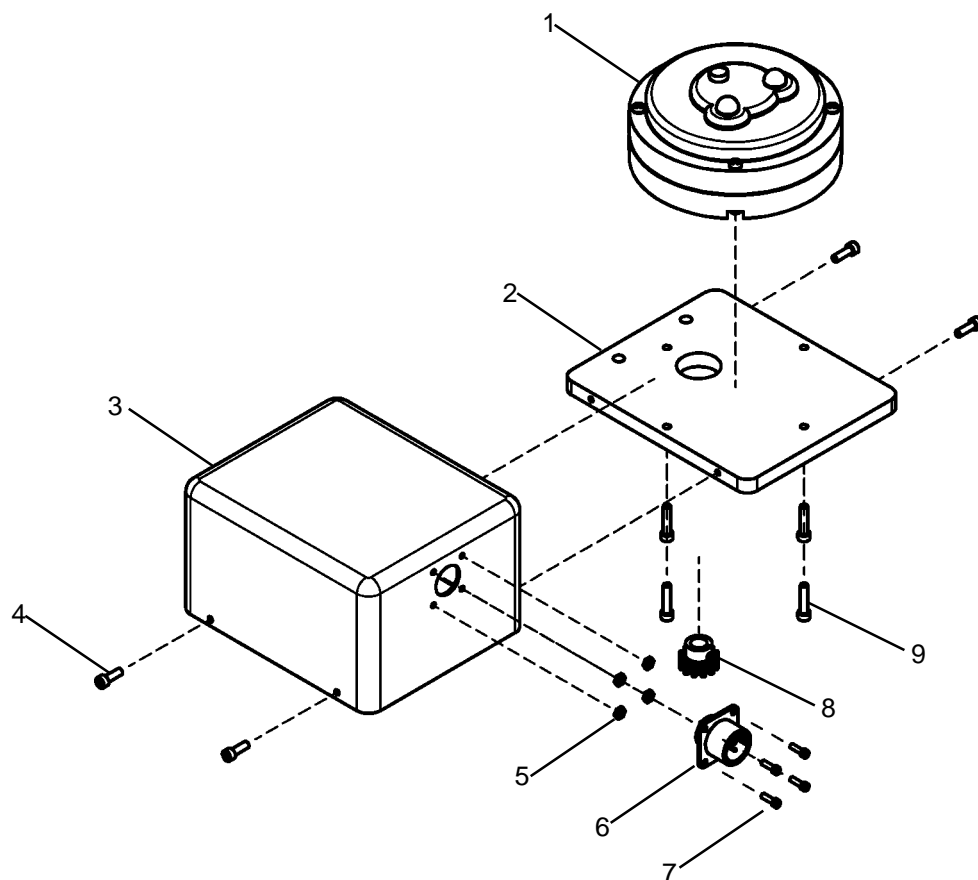

ITEM	QTY	PART No.	DESCRIPTION
1	1	BUG-1550	Gear Motor (150:1)
2	1	CWO-1693	Racker Motor Plate
3	1	CWO-1696	Motor Enclosure
4	4	FAS-0525	Screw, Soc Hd Cap 8-32 x 1/2
5	4	FAS-1305	Hex Nut 4-40
6	1	BUG-9486	Panel Connector, 2T, Male
7	4	FAS-0504	Screw, Soc Hd Cap 4-40 x 3/8
8	1	GOF-3014	Pinion, w/ Key Set Screw
9	4	FAS-0527	Screw, Soc Hd Cap 8-32 x 3/4

ACCESSORIES

CDS-6350 LINEAR WEAVER

The CDS-6350 is a compact weaver unit capable of both linear weave and straight line welding. Intended for use with the Freestanding Torch Support.

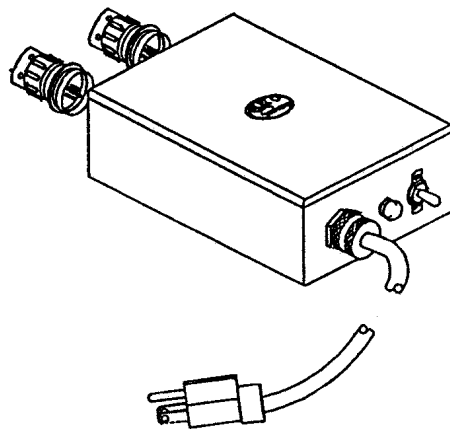
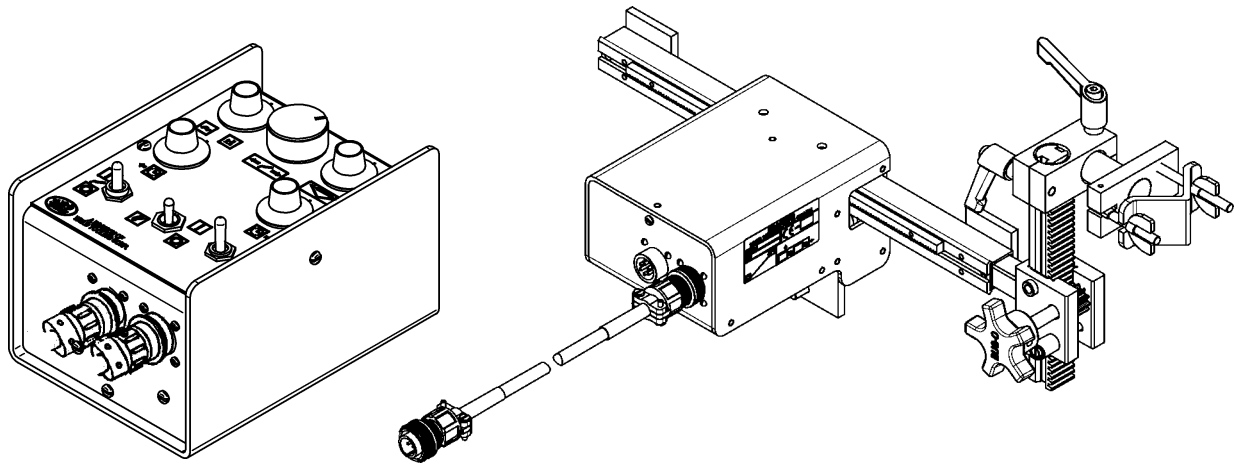

The FTS-1025 shown with Linear Weaver (CDS-6350) and Positioner (BPG-450-L).

ACCESSORIES

BUG-6350 PENDULUM WEAVER

The BUG-6350 pendulum weaver unit is designed for use with the Freestanding Torch Support. It offers both straight line welding and pendulum weave welding. Great for corners.

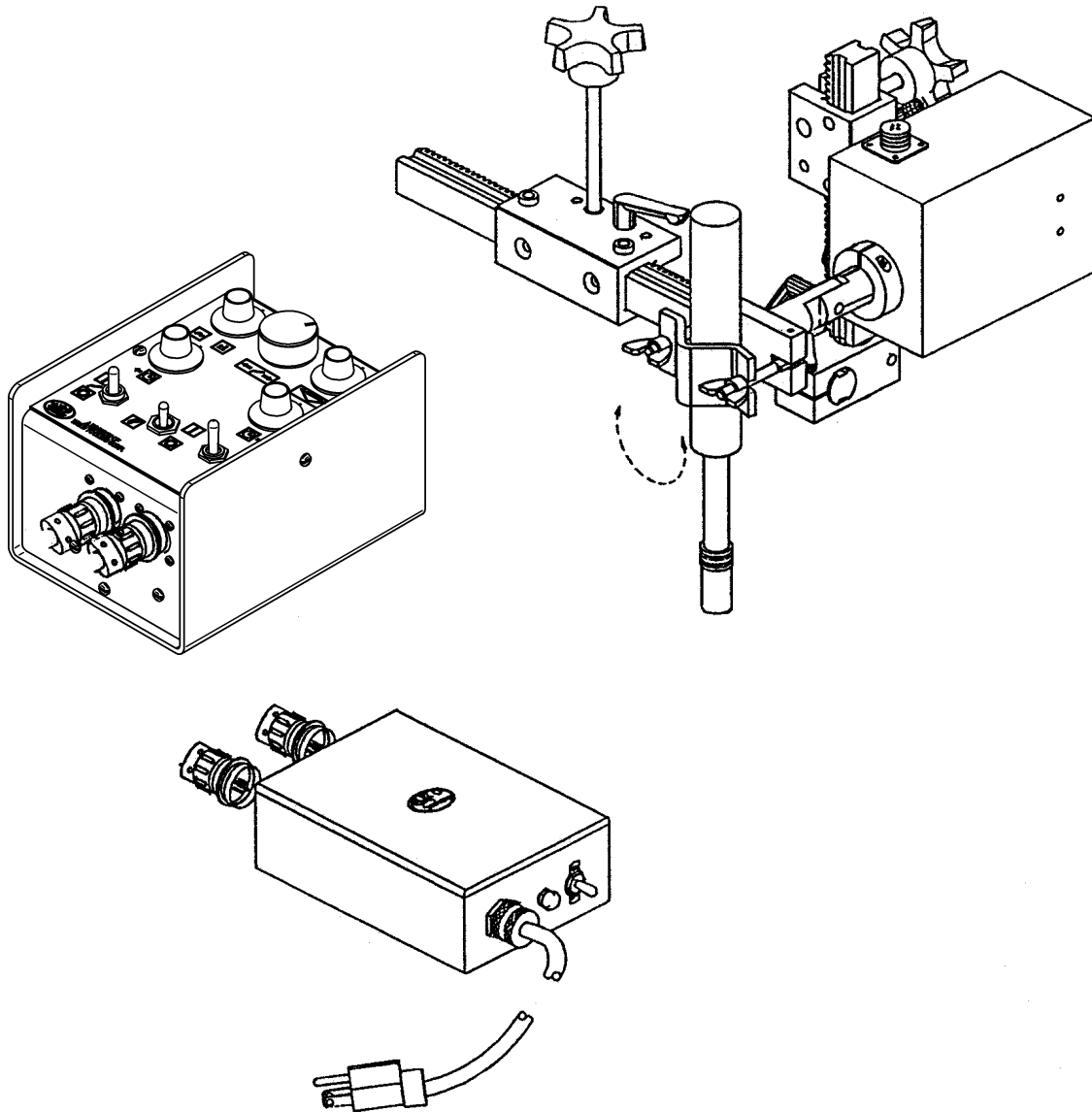

WARRANTY

LIMITED WARRANTY

MODEL _____
SERIAL NO. _____
DATE PURCHASED: _____

FOR A PERIOD OF TWELVE (12) MONTHS FROM DELIVERY, BUG-O SYSTEMS WARRANTS TO THE ORIGINAL PURCHASER (DOES NOT INCLUDE AUTHORIZED DISTRIBUTORS), THAT A NEW MACHINE IS FREE FROM DEFECTS IN MATERIAL AND WORKMANSHIP AND AGREES TO REPAIR OR REPLACE, AT ITS OPTION, ANY DEFECTIVE PARTS OR MACHINE. THIS WARRANTY DOES NOT APPLY TO MACHINES, WHICH AFTER OUR INSPECTION, ARE DETERMINED TO HAVE BEEN DAMAGED DUE TO NEGLIGENCE, ABUSE, OVERLOADING, ACCIDENT OR IMPROPER USAGE. ALL SHIPPING AND HANDLING CHARGES WILL BE PAID BY CUSTOMER.

BUG-O SYSTEMS MAKES NO WARRANTY OF MERCHANTABILITY AND MAKES NO OTHER WARRANTY, EXPRESSED OR IMPLIED, BEYOND THE WARRANTY EXPRESSLY SET FORTH ABOVE. BUYER'S REMEDY FOR BREACH OF WARRANTY, HEREUNDER, SHALL BE LIMITED TO REPAIR OR REPLACEMENT OF NON-CONFORMING PARTS AND MACHINES. UNDER NO CIRCUMSTANCES SHALL CONSEQUENTIAL DAMAGES BE RECOVERABLE.

HOW TO OBTAIN SERVICE:
IF YOU THINK THIS MACHINE IS NOT OPERATING PROPERLY, RE-READ THE INSTRUCTION MANUAL CAREFULLY, THEN CALL YOUR AUTHORIZED BUG-O DEALER/DISTRIBUTOR. IF HE CANNOT GIVE YOU THE NECESSARY SERVICE, WRITE OR PHONE US TO TELL US EXACTLY WHAT DIFFICULTY YOU HAVE EXPERIENCED. BE SURE TO MENTION THE MODEL AND SERIAL NUMBERS.